

TRANSNATIONAL MODEL OF SUSTAINABLE PROTECTION AND CONSERVATION OF HISTORIC RUINS

Best practices handbook

Institutions participating in the elaboration of the publication:

Lublin University of Technology (Poland)

Matej Bel University (Slovakia)

The Institute of Theoretical and Applied Mechanics of The Czech Academy of Sciences (Czech Republic)

Polish National Committee of The International Council on Monuments and Sites Icomos (Poland)

City of Zadar (Croatia)

Links Foundation - Leading Innovation and Knowledge for Society (Italy)

Italian Association for The Council of Municipalities and Regions of Europe (Italy)

Venetian Cluster (Italy)

Municipality of Velenje (Slovenia)

Zadar County Development Agency Zadra Nova (Croatia)

Team of authors:

Bugostaw Szmygin (project coordinator)

Maciej Trochonowicz

Bartosz Szostak

Andrzej Siwek

Anna Fortuna-Marek

Beata Klimek

Katarzyna Drobek

Ivan Murin

Dagmara Majerová

Jana Jačud'ová

Iveta Marková

Kamila Borseková

Anna Vaňová

Dana Benčíková

Ivan Souček

Martin Miňo

Jiří Bláha

Dita Machová

Wei Zhang

Miloš Drdácý

Jakub Novotný

Patrizia Borlizzi

Antonino Frenda

Silvia Soldano

Marco Valle

Raffaella Lioce

Dario Bertocchi

Camilla Ferri

Daniele Sferra

Sergio Calò

Maurizio Malè

Eugenio Tamburrino

Patricija Halilović

Rok Poles

Marija Ževart

Helena Knez

Drago Martinšek

Alenka Rednjak

Marija Brložnik

Rudi Vuzem

Marko Vučina

Jernej Korelc

Darja Plaznik

Danijela Brišnik

Breda Krajnc

Urška Todorovska-Šmajdek

Milana Klemen

Lucija Čakš Orač

Branka Gradišnik

Urška Gaberšek

Krasanka Majer Jurišić

Boris Mostarčić

Iva Papić



Publication within project “RUINS: Sustainable re-use, preservation and modern management of historical ruins in Central Europe - elaboration of integrated model and guidelines based on the synthesis of the best European experiences”, supported by the Interreg CENTRAL EUROPE Programme funded under the European Regional Development Fund.

TRANSNATIONAL MODEL
OF SUSTAINABLE PROTECTION
AND CONSERVATION
OF HISTORIC RUINS

BEST PRACTICES HANDBOOK

*Transnational model of sustainable protection and conservation of historic ruins
Best practice handbook*

Compiled by:

Bogusław Szmygin - Maciej Trochonowicz - Bartosz Szostak - Beata Klimek - Katarzyna Drobek
Lublin University Of Technology



Linguistic correction: Maciej Doksa

Graphic design: ASPEKT Lublin

Publisher: Lublin University of Technology

Printed by: DjaF Naświetlarnia B1+ Agnieszka Furyk

ISBN: 978-83-7947-420-2

Politechnika Lubelska 2020

Table of Contents

1. Introduction.....	7
2. Stocktaking measurements	9
2.1. Traditional measuring techniques	11
2.2. Geodetic method.....	12
2.3. Photographic documentation (traditional, spherical, using a drone)	13
2.4. Photogrammetry	15
2.5. 3D scanning	16
3. <i>In situ</i> testing of materials and structural elements.....	19
3.1. Ground research	19
3.2. Examination of physical features of structural elements.....	25
3.2.1. Endoscopic examination.....	29
3.2.2. Ultrasonic examination	29
3.2.3. Hammer test	30
3.2.4. Electromagnetic examination	31
3.2.5. Sclerometric examination.....	32
3.2.6. Peel strength test (pull-off)	33
3.2.7. Thermovision examination	35
3.2.8. Testing by pressure cushions.....	36
3.2.9. Computer analysis.....	37
3.3. Moisture testing by indirect methods.....	38
3.3.1. Capacitive - dielectric method.....	39
3.3.2. The resistance method	40
3.3.3. The microwave method	41
3.3.4. The chemical method.....	42
3.4. Macroscopic research - “outcrops”	43
3.5. Biological corrosion and vegetation	46
4. Laboratory tests of materials and structural elements.....	55
4.1. Compressive strength test	55
4.2. Tests of physical properties of materials.....	58
4.2.1. Compressive strength and bending strength test.....	58
4.2.2. Abrasion test	61
4.2.3. Water absorption of materials.....	63
4.2.4. Testing the water absorption of natural stone at atmospheric pressure	64
4.2.5. Capillarity of materials	65
4.2.6. Resistance to salt crystallization.....	68
4.2.7. Determination of frost resistance.....	70
4.3. Humidity testing by the gravimetric method.....	72
4.4. Salinity tests	76
5. Studies of historical plasters and painting layers.....	81
5.1. Laboratory tests of mortars.....	81
5.1.1. Macroscopic examination	82
5.1.2. Optical microscope investigation	83
5.1.3. Quality microscopic analysis.....	84
5.1.4. Quantitative microscopic analysis	85
5.1.5. Scanning electron microscope studies (SEM) and analysis (SEM-EDS)	86
5.1.6. Derivatographic study - differential thermal analysis (DTA).....	88
5.1.7. X-ray diffraction test (XRD).....	88

5.2. Laboratory tests of painting layers	89
5.2.1. Optical microscope examination	90
5.2.2. Scanning electron microscope examination (SEM)	91
5.2.3. Research on organic compounds: pigments, dyes, binders in Fourier analysis .	92
5.2.4. Spectrometry test - the X-ray fluorescence (XRF).....	93
6. Good and bad examples of conservation of ruined sites.....	95
7. Bibliography	143

Disclaimer

The authors are responsible for the choice and presentation of the facts contained in this publication and for the opinions expressed therein.

1. Introduction

The assessment of the technical condition of historical buildings is one of the most important conservation problems. The assessment of the technical condition is the basis for the fundamental decisions related to the protection of the monument - from determining the scope of interference needed in the form and substance of the monument, through planning the conservation and renovation works, to choosing the form of adaptation of the object to modern utility functions. Of course, in each of these areas the assessment of the technical condition is not the only factor, but it is always an important factor, and often even a decisive one.

In the case of monuments of construction and architecture, the assessment of technical condition is conditioned on two levels. The first determinant are problems related to the state of monuments as buildings. These are strictly technical issues - geotechnical, constructional, material, technological, etc. In the case of these engineering problems, the historic building is treated like any other building. The parameters determining the condition of building materials and structure are important, e.g., strength, humidity, salinity, adhesiveness, insulation, cracking, deflection, and settlement. In the study of these parameters, the historical character of the building does not really matter.

However, historical values mean that the assessment of the technical condition of historical buildings cannot be reduced only to engineering issues. The need to preserve the object in accordance with the requirements of authenticity and integrity - that is, the overriding conservation rules - often also influences the scope of the technical assessment. The necessity to preserve the authentic elements and materials of the monument (instead of replacing them) may require extending the scope of research. Similar requirements may also result from the adoption of certain technologies or conservational materials that are imposed by the historical character of the object. As a result, technical inspections of historical buildings are often more extensive and more accurate, and they may require in situ and a laboratory analysis.

Additional conditions resulting from the need to carry out conservation works (apart from construction and renovation works) and the special value of historical buildings, therefore, make the assessment of their technical condition an important, responsible and often non-obvious task. Thus, creating specific standards for such analyses is fully justified, especially in relation to atypical groups of monuments, such as historical ruins.

The great importance that diagnostics and assessment of their technical condition have for the proper protection and management of historical ruins fully justifies the creation of a publication devoted to this subject. As part of the RUINS - Sustainable re-use, preservation and modern management of historical ruins in Central Europe project, separate guides are devoted to the three main areas of effective protection of historical ruins - management, use and assessment of the technical condition. Each of these publications is a joint work of all the project partners, but the main participants in their creation were partners responsible for the given issues. In the case of a guide on the assessment of technical condition, the partner was Lublin University of Technology.

At the Faculty of Civil Engineering and Architecture of Lublin University of Technology, the Department of Monuments Conservation is a unit specialized in technical issues of protection of buildings and their architecture. The unit has been working for a dozen or so years to standardize documentation, assess the value and the technical condition of historical buildings. First of all, the so-called Monument Technical Assessment Cards (expanded forms in a tabular form) that allow to comprehensively compare information relevant to documenting and assessing the technical condition of a historical object.

The diversity of different typological groups of monuments makes it unnecessary to develop a universal card. Therefore, Cards for selected groups of monuments are successively being developed. So far, Cards for manors and tenement houses, wooden buildings, and historical ruins have been created.

Experiences in the analysis of various monuments made using the Assessment Cards have shown that it is also justified to provide a comprehensive overview of the research that serves these assessments. This guide, *Technical Investigations of Historic Ruins*, contains a set of tests and equipment that are needed to make a comprehensive assessment of the technical condition of this type of monuments. It is therefore a publication that supplements the standard of technical evaluation of historical ruins. Together with the Assessment Card, it can be the basis for a comprehensive assessment and documentation of the technical condition of a ruin, and thus constitute the basis for planning any renovation and conservation works to protect and develop it.

The publication entitled *Technical Investigations of Historic Ruins* consists of 4 essential parts, which were separated due to the characteristics of the research presented in them. In Part 5, more than a dozen examples of good and bad practices have been collected and selected by the RUINS project partners.

The first part concerns inventory measurements. This is an important part because the inventory of a monument has a double meaning. First, the inventory documents the current form of the ruin, which, in the face of the ongoing destruction process, is constantly changing. It is therefore the consolidation of a state that will no longer exist. Secondly, the inventory is the basis for all conservation, design, and renovation documentation. This part presents the most commonly used measurement and documentation techniques - traditional measurement methods, geodetic methods, photographic methods, photogrammetry, laser scans, and photographs taken with the use of drones.

The second part presents in situ research of materials and structure of the object in ruin. In addition to the soil substrate research, two sections discuss the physical characteristics of the structure and humidity tests. The examination of the physical features of the constructional elements serves directly to assess their technical condition. On the other hand, humidity tests, which basically serve to assess the state of the building material, also allow to determine the causes of moisture in the entire building. However, this requires the development of moisture maps of the object, and therefore performing numerous measurements that can be made with several methods. This part also presents methods for testing damages caused by biological corrosion, an important factor in the process of ruin destruction.

The third part also concerns the research of materials and structures that are carried out in the laboratory. These tests concern mainly the physical characteristics of the materials from which the ruined building was constructed, including the mortar which connected stone blocks or bricks. This part also presents methods for testing the degree of salinity of ruins elements.

The fourth part is devoted to the research of plasters and painting layers. There are not many plasters and painting layers in objects in ruin because of their age and lack of protection. However, they have more value, and therefore their adequate protection is of utter importance.

Most of the research presented in the publication has been described according to a similar scheme. It includes the presentation of the nature of the study, its implementation and the form of presenting the results. The comprehensive nature of the publication makes the presentation of the research synthetic, which is why it has been supplemented with a bibliography.

In addition, it should be added that the technical studies presented in the guide should be coordinated with historical, archaeological and architectural research. Only the whole group of these tests creates an image of the object and allows to determine its values. And it is only on this basis that it is possible to responsibly plan conservation works and the program of modern development of the historical ruin.

2. Stocktaking measurements

The measuring-drawing inventory is the most popular, and at the same time the basic form of documentation of monuments. Due to the lack of precise information about objects which are recognized as ruins, it is necessary to prepare accurate stocktaking. There is a need to develop an analysis, which would consider their specificity and condition of maintenance. Performing stocktaking documentation is an action connected with conservation, which should be prepared before various tests and projects. This is also extremely important because of the possibility of monitoring the facility. Accurate documentation and stocktaking measurements of objects are a basis for any conservation activities.

The stocktaking consists mainly in preparing measurement drawings, as well as a description of the current maintenance of the object or its part. Its aim is to get to know the monument. Regardless of the adopted method of the stocktaking of a facility, it starts with carrying out a field inspection. Only after a precise inspection can the stocktaking measurements be performed. This analysis should be conducted in a specific way. It should take into account all visible deformations, transformations, scratches, cracks, visible details, and sometimes transformations of an object over a period of time. Accurate mapping of the real spatial layout and determination of the technical and functional structure of objects or its parts are the purposes of stocktaking. Based on various measurements, architectural documentation of the facility is prepared.

The stocktaking constitutes an initial material to execute any works on the object, it enables carrying out research and analyses of the ruins. The stocktaking fulfils a function of registering the condition of an object at a given time. The stocktaking measurements are a basis for drawing up construction and implementation projects, and at a later time for calculation of construction and conservation works. The effects of the stocktaking works are presented in descriptive, graphic, and photographic forms.

The stocktaking is required, among other things, for:

- extension of an object,
- adding a superstructure to an object,
- renovation of a building,
- dismantling of a historic structure,
- assessment of a technical condition.

Scale of drawings

The stocktaking of facilities should be performed in a proper scale, in the case of masonry buildings usually in 1:50. The scope of the stocktaking is not clearly defined and largely depends on the purpose which it is drawn up for. If the drawings are to be attached only to the cards, they should be schematic and take into account only basic dimensions. These studies could be prepared even in a 1:100 scale due to the low degree of accuracy necessary. The measuring-drawing documentation made for research and conservations needs should be drawn up more precisely. The use of a 1:50 scale results in greater accuracy of the drawing. Both cross-sections and facades should be detailed, which is difficult when using the 1:100 scale. Details should be drawn up in a scale which enables to show every elements of its content in a precise way while maintaining high clarity of the drawing, therefore the appropriate scale is 1:1, 1:10, possibly 1:20. It is therefore stated that the more extensive purpose of the research, the more detailed the documentation should be.

The scope of the stocktaking

It should be also remembered that an integral part of the measurement and drawing documentation is the descriptive part, which consists of a description of the measurement methods and the characteristics of the object. It is also necessary to make the photographic documentation.

The scope of the stocktaking documentation required may include:

- a situational drawing,
- plans of all storeys,
- vertical sections,
- drawings of facades,
- drawings of historical details,
- photographic documentation,
- technical description, taking into account the location of the facility, its type and nature, the number of storeys, the height of the building and its surface,
- description of materials from which individual building elements were made.

Depending on the subsequent purpose of the stocktaking, the issue of its implementation may also be presented in a completely different way. Due to the fact that the objects in the ruin are so diverse, it is not possible to unambiguously determine the number of drawings which are necessary to make. Typically, the spatial layout of the object requires several vertical sections. Drawings must take into account all the historic details, which should be marked both on projections and on more accurate drawings in a correspondingly larger scale.

Norms and technical guidelines applicable in the scope of the stocktaking

As regards the provisions concerning the stocktaking, there are many standards related to the preparation of the construction drawings and the room size measurements, but they will not be discussed due to their high level of detail. Due to the fact that objects in ruin are atypical objects, it is not possible to apply all the applicable standards simultaneously. These standards in the case of ruins will not find such a great use, because of their specificity.

Objects in ruin are so unique that we are not able to even refer to the level of sampling. The horizontal cutting plane will be determined on the basis of the object analysis and selection of the most individual features. A measurement made at the level of 1 m may not work because there will be no important elements or holes. Then it will be necessary to perform it on another, perhaps a lot higher level.

As for the application of norms, it really depends on the specificity of the building and its state of preservation. Norms only appear as guidelines for development, but it is not possible to use them in every situation. They only set certain standards. Therefore, in many cases derogations will be necessary.

The issues related to the measuring-drawing stocktaking

Usually, many problems arise during the stocktaking action. The main and most problematic issue that arises while stocktaking is the lack of its standardization. Incorrect recognition of the object, a poor measurement method or inadequate drawing cause many errors and shortcomings.

The basic problem of a manual measurement is the course of the measurement process, because the measurements collected cannot fully reflect the actual structure. The reason for this is not taking into account the comparison levels, diagonals, and polygons. This results in a schematic approach to drawings without taking distortions into account. A misplaced projection will cause errors in subsequent drawings. The documentation will bear many errors and distorted dimensions. The dimensions interpolation is also incorrect.

A frequent mistake that is made when developing measurement and drawing documentation of the facility is failure to comply with standards, especially those that define graphic signs appearing in architectural drawings. In many cases, it is also forgotten that the textual part and photographic documentation are integral parts of the drawing documentation.

Most of the errors that occur during the creation of the stocktaking result, to a large extent, from the fact that there is no regulation regarding the execution of the stocktaking documentation. It is quite contrary in the case of creating the project documentation, conservation and restoration studies, architectural and conservation studies, or conservation supervision. The measuring-drawing stocktaking is not included in the quality control. This situation means that the submitted documentation may be incomplete or may have many shortcomings and measurement deficiencies.

2.1. Traditional measuring techniques

The basic method of performing the stocktaking is the traditional manual measurement. This is the oldest, easiest and most time sufficient way of performing measurements for most of the ruins. The accuracy scale is significant for creating the object documentation. For making traditional measurements, tapes, scoops, and laser rangefinders are used. The information obtained should be converted into the drawing documentation by using traditional and computer methods.

As already mentioned, the stocktaking begins with a field inspection, then a measuring sketch is prepared. To create horizontal projections, measurements are taken from all the walls of the rooms and their elements, including details. Measurements should be performed at one height. To avoid measurement errors, the so-called “string record” should be used, that is, successive reading of dimensions from the characteristic points on the wall. It should be remembered that the long walls should be measured twice and the floor level relative to the reference point adopted for the given object or its fragment should be given. The thickness of the walls should be measured in places where the full dimension can be obtained directly or it can be made in sections ¹. In rooms of irregular shape, diagonals should be measured. This allows you to specify a more accurate room geometry.

When performing measurements of the horizontal projections, dimensions are given in the light of all openings and recesses, the height of window sills, and vaults. Door and window openings should be measured both in the light of the opening and the frame. In the direct stocktaking method, it is extremely important to coordinate the projections of all storeys with the use of communication divisions and openings. Dimensions should be given only if they have been measured directly and they do not result from calculations.

The facade measurements should be made at the very end, based on projections and designated height of characteristic points. When making the stocktaking drawings of the façade, particular attention should be paid to all kinds of damage, losses, cracks, and secondary materials. It is important to precisely determine their occurrence and describe it accordingly. Both rooms and spaces that are not available for measurement should be marked and described in the drawings, and for elements located at significant heights, the way in which they were drawn is additionally given.

The result of the stocktaking made using the traditional method is the stocktaking note, created during the stay at the facility. It consists of drawings made during measurements together with the dimensions and details drawn. On the basis of the stocktaking note, appropriate documentation of the object is created later.

¹ Uściłowicz J., Standards of conservation documentation of wooden architecture facilities as a basis for monitoring and management, Documentation and the monitoring in managing timber objects in Krzysztof Kluk Museum of Agriculture in Ciechanowiec and the Ryfylke Museum, Krzysztof Kluk Museum of Agriculture in Ciechanowiec, 2015, pp. 43-67

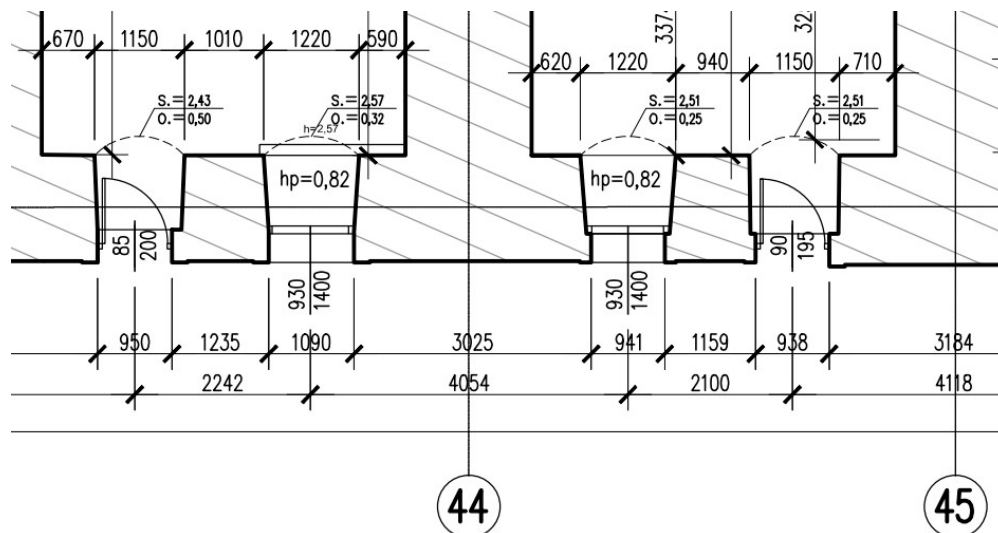

Figure 1. Fragment of the final stocktaking of Kłodzko Donjon Fortress - a horizontal cross-section of the "0" storey - the stocktaking made using a computer drawing software.

The traditional method is extremely time-consuming and requires a lot of work, and also does not always give the opportunity to accurately measure all items due to their unavailability. Measurements performed in a manual manner do not give the possibility to map the projection geometry, therefore this method is recommended only for simple objects. There is also a high risk of measurement error by the person performing it. The advantage of the traditional measurement method is the possibility of making a detailed analysis of the structure.



Photo 1. Traditional measurements of the elevation of the Kłodzko Donjon Fortress

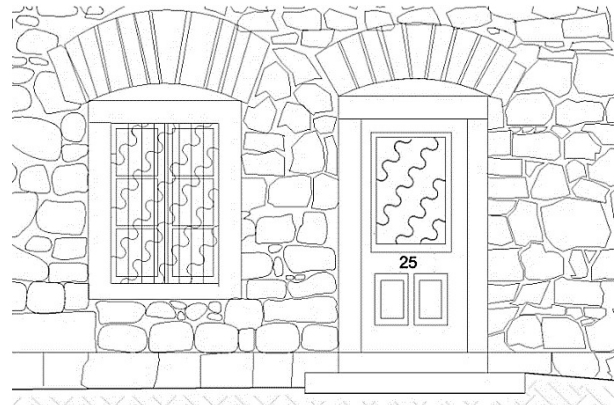

Figure 2. View of the elevation of the Kłodzko Fortress made after traditional measurements

2.2. Geodetic method

The geodetic methods are mainly used to measure the geometry of objects and conduct research on deformations and deflections of the object. In the case of the object stocktaking, this method is time-consuming, therefore, it is recommended to use the geodetic method only for measuring complex geometry, difficult access or significant height of objects.

When assessing the technical condition of an object, the geodetic method is used to investigate all kinds of deformations and displacements of elements in the facility. Using the geodetic equipment with very high accuracy, deviations from the vertical or subsidence of building fragments can be estimated. Currently, it is the most commonly used displacement survey method. An alternative to this method may be the 3D scanning described in paragraph 2.3.

Two geodetic methods can be distinguished to assist in the stocktaking. One of them uses a leveler for this purpose, the other uses a tachymeter. The leveler is a geodetic instrument that allows measuring the height difference between terrain ordinates.

Among the tachymeters, instruments without the use of a mirror are often used for measuring distances. Thanks to them it is possible to determine the geometry of the object and to measure the photogrammetric matrix. Therefore, the reflectorless tachymeter can be used to create architectural stocktaking.

The object stocktaking using a tachymeter is based on measuring angles and distances. The measurement of the length of the section is possible thanks to the precise laser rangefinder, which is built into the device. The distance is determined from the increments of coordinates between the measuring instrument and the measured point. The tachymeter has the capability to measure selected points, which define the characteristic places on the site.

The tachymeter combined with the appropriate software can significantly speed up the work and, above all, ensure high accuracy of measurements. Measurements taken with a tachymeter will work to create projections, cross-sections, and simple elevations. It is also possible to create a full stocktaking using this instrument, however, a huge downside of this method is the large amount of time which is needed to spend on the site. In this case, the documentation is created on an ongoing basis, so it is also possible to correct any errors on an ongoing basis. Before starting work, the cutting planes should be precisely determined. The result of this are drawings created in computer drawing software, directly on the spot.

The advantage of this method is its precision. Using the tachymeter, in contrast to the traditional method, it is possible to make accurate measurements of large objects. Depending on the model of the reflectorless tachymeter, the range of the instrument is up to 2000 m, and the accuracy, depending on the distance, is approximately 2 to 5 mm. The accuracy of the measurements may vary depending on the material from which the beam will be reflected. With smooth materials (e.g., marble) and with a small angle of incidence of the laser beam, the measurement results can significantly differ from the actual state².

The tachymetric method itself is time-consuming, so it would be good to combine the two methods, i.e. both geodetic and manual measurements. Thanks to the tachymeter, it is possible to obtain wall geometry, while measuring with a ruler or a rangefinder it is possible to place elements more accurately. By combining these two methods, it is possible to accurately replicate the actual appearance of the ruin.

2.3. Photographic documentation (traditional, spherical, using a drone)

The photographic documentation is an indispensable element for conducting a detailed analysis of the facility and complementary material for the drawing documentation.

The pictures should be taken in the best possible resolution and quality. The photographic documentation should also be made using the photogrammetric stocktaking, as a supplement to the measurement information.

Photographic documentation should consist of:

- a list of photos,
- a list of pictures numbered and described in detail,
- a graphic presentation of the plan of photographic positions.

The photo catalog should include photographs made in such a way as to show the general characteristics of the ruin i.e. its shape, its location in space, all elevations and details. The order of photos should ensure easy orientation in the facility and allow quick location of the photo in the documentation³.

² Kwoczyńska B., Opracowanie obiektów architektonicznych z wykorzystaniem metod stosowanych w fotogrametrii cyfrowej, Infrastruktura i ekologia terenów wiejskich, nr 3/2010, Polska Akademia Nauk, Oddział w Krakowie, s.65-74

³ Wytyczne Techniczne G-3.4, Inwentaryzacja zespołów urbanistycznych, zespołów zieleni i obiektów architektury, GUGiK, Warszawa, 1981

There are three basic photo sets:

- I - photographs showing the object with the surroundings; including full frames, depicting the entire object, showing the context, general characteristics of the ruin its embedding in space, full facades,
- II - photographs showing certain elements of the object, i.e., the entire window or door element
- III - photographs showing close-ups related to the detail, i.e., cracks, discolorations, damage, etc.

Depending on the devices used, the photographic stocktaking can be divided into: traditional photography, spherical photography, and drone photography.

Traditional photography

The traditional photography is made using various types of cameras. The equipment used for taking pictures is selected depending on the user's skills and preferences.

The photographic documentation should present the whole object and its parts, details, characteristic elements, elevations, and elements of architectural decor. Photographs should be taken from characteristic viewpoints to enable the display of the whole object or its fragments. Photos of the façade, characteristic elements, openings, materials, and wall damage should be made in a similar way to the orthogonal one, in order to avoid distortions of the object. Photographs of details should be made with a clear comparative scale.

Spherical photography

It is a modern type of photography. With a view range of 360° horizontally and 180° vertically, it allows to rotate around its own axis and document the image down and straight up. It gives the effect of free looking around. In contrast to traditional static photography, which only shows a slice of reality, the spherical photography is not limited by the so-called frame.

The spherical photography is performed using a wide-screen camera, 360° camera, or individual photos can be combined by using computer software. Photographs should be made in such a way as to have control points allowing for the connection of frames. Therefore, it is necessary that successive photographs overlap in about 20-40%.

Photographs taken by the 360° camera and viewed without using the appropriate software creates a flat image (see Photo 3). The effect of uninterrupted viewing is possible only with the use of computer software. Photographs are created in a good resolution, which allows for close-ups. By zooming in, the image becomes flat.

The spherical photography is an ideal complementary stocktaking material that also allows to create a virtual walk around the object.



Photo 2. Photograph taken from the 360° camera, flat image view.

Photography taken by drone

Unmanned aerial vehicles, i.e. drones, are remotely controlled by the operator, although there are also models that move completely autonomously. Undoubtedly, they have enormous potential, because they enable to perform many works that are unattainable using traditional methods.

This technology, in the stocktaking of objects in ruin, allows to reach places that are impossible to photograph using traditional photographic documentation methods. Drones allow the whole body of the building to be covered from above and they are thus helpful in determining the exact shape of the ruin.



Photo 3. A photo of a wall crown made with the help of a drone.

2.4. Photogrammetry

Photogrammetry, like traditional photography, consists in taking pictures, however, in the pictures presented there are no geometric disturbances caused by the perspective. Thanks to photogrammetry, it is possible to cover difficult-to-access elements with measurements, because image registration takes place without physical contact with the building⁴.

Photogrammetry is a technique for making measurements, recreating shapes, sizes and mutual relations between the location of objects in a given area on the basis of photogrammetric photographs called photograms. The image recorded using the photogrammetric method reflects much more information than traditional measurements would. Therefore, this information is an extremely valuable archival material, especially in the case of objects in ruins⁵.

To create a photogrammetric study, the object should be photographed from at least two points. This allows for a mathematical reproduction of the position and orientation of each of these photographs in space, and it is also possible to see the image of the object spatially. In connection with the geodetic determination of coordinates of points reproduced in photographs, it is possible to place the obtained three-dimensional images in space.

Photogrammetry is an accurate technique for stocktaking of objects. If the camera is placed at a distance of 20 m from the object, the measurement accuracy will be 1 cm. The measurements accuracy can be increased by putting the camera closer to the object being tested⁶. The effects of the photogrammetric analysis are vector drawings. This method is extremely helpful in the

4 Bar E., Faldrowicz J., Dokumentowanie zabytków architektury metodami fotogrametrycznymi i skaningu laserowego, Acta Scientifica Academiae Ostroviensis, nr 34, 2010, s. 5-14

5 <http://www.wrogeo.pl/pl/fotogrametria.html>, 24.07.2018

6 <http://geo-metric.com/fotogrametria-cyfrowa>, 24.07.2018

technical documentation of the façade and the external outline of the building. Photogrammetry allows for precise capturing of surfaces decorated with details, which makes it useful in the case of historic buildings.

Facade views made on the basis of this method can serve as a basis for creating chronological stratification at further stages of research, while in the case of restoration and conservation works, they can be used in the stocktaking of damages.

Basically, converting photogrammetric images into stocktaking drawings is very time-consuming. The pictures should be drawn each time. The stocktaking created in the photogrammetry method can also function as plans, because their execution is consistent with the scale of the object.

2.5.3D scanning

Laser scanning, from a technical point of view, is one of the most accurate ways of performing the stocktaking measurements. It is made using a laser scanner and is used mainly for large, complex objects with a special historical value.

Information obtained in digital form during scanning can be stored on external hard drives. Due to the very high resolution and accuracy of scanning, the cloud of points created is a faithful representation of the real state. The information archived in this way can be used later in other works, more detailed than the general stocktaking. At the beginning, the scan is a collection of points needed to create a model and flat figures. It can be used, e.g., during conservation works related to an architectural detail or a detailed assessment of the technical condition of wall damage.



Photo 4. Leica ScanStation C10 while taking measurements

The principle of operation of the scanning device is based on measuring the distance of the object from the device. The scanner, thanks to the presence of a special optical system, sends laser beams that are reflected by an obstacle. When returning to the photodiode, information about the reflection time is transmitted, which makes it possible to determine the distance of the given point from the device. On this basis, it is possible to write the XYZ coordinates for each point, which, when collected together, creates a spatial collection called as the “cloud of points”. Such cloud of points is a digital representation of the object covered by the stocktaking. After proper data processing, it is possible to create a 3D model of the object scanned⁷.

Measurement of many points and their mutual spatial relations is possible thanks to the scanner’s rotation around the axis directed perpendicularly to the base plane and simultaneous rotation of the head around the parallel axis.

Additional information provided by the laser is the intensity of the light reflection, which allows for

⁷ [Gołembnik A., Rola nowych technik dokumentacyjno-pomiarowych w interdyscyplinarnych działaniach badawczo-konserwatorskich, Wiadomości Konserwatorskie, nr 40/2014, s. 83-93

differentiation of elements and surfaces in the object measured. Very helpful when developing the cloud of points, is the ability to take photos by scanning devices. Photo processors and the XYZ coordinates assign the RGB (color) values to the points to give the cloud a realistic texture. In fact, the image that is created from the cloud of points becomes an active and three-dimensional model mapped in a 1:1 scale.



Figure 3. The cloud of points, which was created as a result of the preparation of spatial data obtained from the Leica C10 scanner - Janowiec castle

Laser scanners provide the opportunity to obtain much more data in a much smaller time interval than measurements performed in traditional ways. The stocktaking made with the use of the 3D scanning allows to create a detailed study, which is of great importance when working on objects in ruin.

The large laser range, depending on the model, enables efficient measurement of large-scale objects. This is a significant asset when performing the stocktaking of large ensembles or hard-to-reach ones due to their location and the building area. The density of points acquired facilitates detailed mapping of the wall structure and the geometry of spatial elements. Creation of the cloud of points for the entire facility is possible thanks to combining individual sets with defined field targets or common points determined during processing with dedicated computer software.

Similarly to the aforementioned stocktaking methods, the information obtained from laser scanning has to be prepared and presented in the form of technical drawings. However, the probability of making a mistake when mapping geometry or the thickness of building partitions is extremely small.

The main advantage of using the laser scanners is the ratio of working time to accuracy achieved when mapping important object parameters. The scanner is such an accurate device that it is able to capture anomalies that are not observable with the naked eye. Thanks to this, it is possible to make many useful analyses and detect places where damage and deformation occur. It is worth remembering, however, that the laser beam is not always able to reach all places and can be reflected from an accidental element.

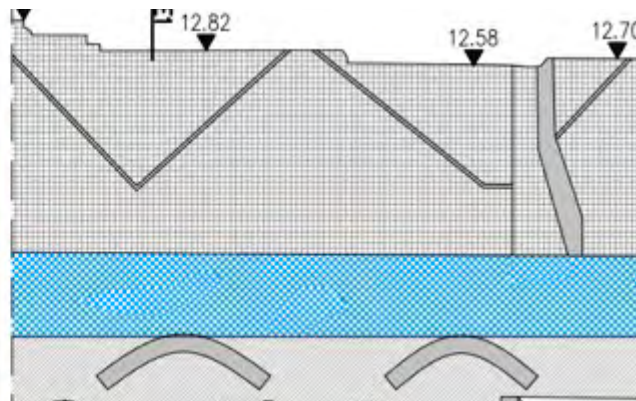
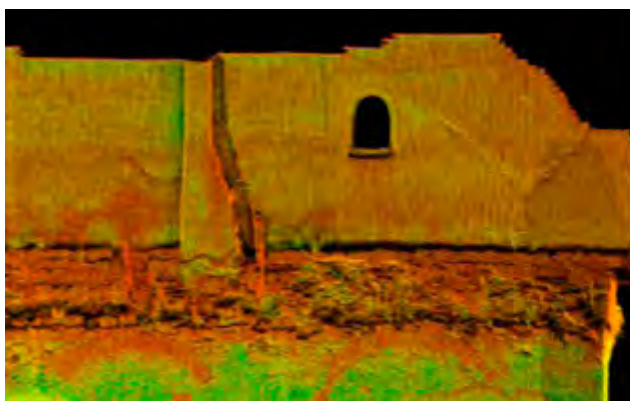

Figure 4. A view of the facade of Janowiec castle developed on the basis of a 3D scan

Due to the accuracy of the 3D scanner, this method is very useful in the process of documenting

an object in ruin. The information that can be received through scanning gives the opportunity to use it for various purposes, including design. The ability to monitor changes is valuable in the case of objects in ruin, which is why it is important to perform a scan in the largest possible concentration of the cloud of points.

3. *In situ* testing of materials and structural elements

3.1. Ground research

The durability of construction objects, in addition to the applied constructional solutions and construction materials used, depends to a large extent on the local ground and water conditions, which consists of the types of soil and their spatial layout as well as dynamics and chemistry of the waters occurring in them. These abiotic elements of the environment, which cooperate with the building, only seemingly are immutable and permanent over time. The variability of foundation conditions may result from both internal interactions of the geological environment, climate changes, biocenotic changes as well as more and more intense anthropogenic impacts.

Nowadays, the design of foundations of building structures and stability assessment of existing ones, including historic objects, is based on the geological-engineering or geotechnical methodology included in the legal framework.

The need for geotechnical and geological-engineering studies of the ground and water substrata of historical objects usually results in emergency situations of buildings or the necessity of changing loads (usually weighting) of foundations as a part of renovation or revalorisation works. In the first case, the aim of the research is to determine the cause of damage in the long-term use of the site with confirmation or exclusion of geotechnical reasons. In the second case, the goal is to establish the ground parameters to determine additional foundation settlements associated with the increase in loads. Obtaining the right solutions is connected with good assessment of both the operation and requirements of the building object as well as the properties of the substrata, which in turn affects the scope and type of necessary geological and geotechnical tests. Choosing the right procedure is additionally complicated by the fact that the construction site in the area of the historic building is usually subject to conservation protection, archaeological, and archaeological-architectural works conducted within it, its natural and historical (successive stratification) evolution distorting its large parts. Therefore, at the initial stage of research, in addition to the routine analysis of archival geological, hydrogeological, and geotechnical documentation, it is appropriate to study the archaeological documentation (excavations) and locate them in the environment of the construction substrate. Archaeological excavations are usually completed vertically after reaching the original soil, that is the native soil. This is usually also the level of foundation of the deepest elements of the object. Thus, there is always a need to make a deeper diagnosis, because stresses resulting from the object's loads affect much deeper ground, and the sources and mechanisms of water environment impact from groundwater are usually below the foundation level. An important element of the diagnosis is also a thorough analysis of ecological conditions of the facility's surroundings, especially in terms of existence (or documented removal) of trees. Taking into account these observations, the further course of proceedings in the recognition of ground and water conditions of the foundations of a historic object, saturation of points and research profiles is analogous to routine geological and engineering studies, which is included in the monograph "Principles of geological and engineering documentation (in light of requirements of the Eurocode 7)" [ed. E. Majer, M. Sokołowska, Z. Frankowski, PIG-PIB, 2018]. However, it is advisable, due to the conservation sensitivity, to use less invasive research methods. In place of a large number of drilling and excavations, alternative geophysical methods should be used. Instead of dynamic probings, static probings or trial loads should be used. Due to the possibility of occurrence of earlier developments in the vicinity of the object, underground functional elements, or layers of cultural levels (embankments), GPR, electrofusion, and microgravimetric methods seem to be particularly

useful. The photo-interpretation of aerial photographs is helpful in the analysis of ground and water conditions of the object's area, and the interpretation of archival photographs and historical cartographic documentation is helpful to assess the cooperation of the object with the ground and the surroundings (biocenosis).

The set of information obtained as a result of analyses and research conducted should allow to develop a sufficiently correct forecast of the phenomena and their development over time that will occur in the ground and in the construction of an object interacting with this ground. The forecast should be given in such a form that it can be used by the designer, contractor, and user of the facility.

Degree of ground and water conditions complexity and geotechnical category

The geotechnical category is a derivative of soil and water conditions, and structural factors of the existing or planned facility, as well as its impacts and the degree of its complexity, the level of general safety, material and historical value, and environmental impacts. The geotechnical category of the object or its part is determined by the designer after substantive consultation with a geotechnician or geologist. The geotechnical category is an assessment of the ground substratum at the current level of recognition of soil and water conditions and may change after obtaining additional information or changes in the construction design.

The geotechnical category determines the scope of necessary diagnosis as well as geological-engineering and geotechnical tests. Historic buildings, regardless of the degree of complexity of the ground, are considered in the third geotechnical category, which requires preparation of the ground study documentation (Ground Investigation Report - GIR, according to PN-EN 1997-2) and/or, additionally, geological and engineering documentation, according to the geological and mining law. A perfect complement to routine geotechnical and geological-engineering documentation for large objects and historical facilities is the execution of the environmental impact reports, which, alongside the characteristics of the abiotic environment, also bring potential impacts of biocenoses and anthropogenic pressures, which is particularly important when formulating long-term stability and durability forecasts of historic objects. Under the current regulations, ground and water substrate testing of historic objects requires the documentation of substrate testing and/or geological-engineering documentation (GED/DGI).

The documentation of ground tests (GIR) is a document containing the results of field and laboratory tests, interpretation of tests, a combination of the obtained and derived values of geotechnical parameters, a description of the layers separated, a geological model, geotechnical assessment, and recommendations for further works and monitoring. Ground testing documentation is not subject to administrative and archiving procedures.

Stages of geological-engineering documentation

The documentation describes the methods of conduct determined on the basis of legal regulations, standards, and good engineering practices consisting on:

- gathering available information about the area, important for the planned construction project within the historic facility
- the design and implementation of field and laboratory research
- the analysis and interpretation as well as the assessment of the obtained research results
- the visualization and description of the results of the information collected and the tests carried out
- archiving the research results

Tab. 1st *The documenting process in accordance with the provisions of geological law and recommendations of the Eurocode 7 consists of several stages.*

Stage 1	Collection of relevant and available information about the site and its analysis. At this stage, these materials should be confronted with the actual state as part of the field inspection and the environmental research. The type and scope of the necessary research is dependent on the quantity and quality of the data collected at this stage.
Stage 2	The research design results from the appropriate research goal. Detailed guidelines on the scope of projects are included in the regulation on specific requirements for the Geological Works Designs (GWD) (Journal of Laws of 2015, item 964), and the content of research programs - Eurocode 7.
Stage 3	Performing research. Geological works, their type and quantity are carried out on the basis of a research project approved by the competent geological administration authority. Ground testing is performed on the basis of a geotechnical survey or opinion that does not require an administrative decision. In the case of historical buildings, both GWD and the research program are subject to consultations and opinions by the competent Office of the Conservation Officer, and a permit for their execution must be obtained.
Stage 4	Analysis, processing and interpretation of the results of field and laboratory research is aimed at creating a geological model, a system of soil layers, hydrogeological and geodynamic conditions as well as the measured and determined geotechnical values. Additionally, the geotechnical (construction) project should include a combination of characteristic and computational values for the geological model obtained.
Stage 5	Evaluation of test results. The recommendations and rules for the evaluation of research results are discussed in detail by the Eurocode 7. The quality of this geological-engineering documentation (GED) and/or ground study (GIR) affects the safety of the design, construction, and operation of the site.
Stage 6	Presentation of test results. The results of geological-engineering surveys are presented in the form of geological-engineering documentation (GED) in accordance with the Geological and Mining Law (Regulation of the Minister of the Environment of November 18, 2016 on geological-engineering documentation). The ground (GIR) test results are presented in accordance with the Construction Law (Eurocode 7). Both forms of documentation consist of text and graphics.
Stage 7	Collection and archiving of research results. In accordance with the provisions of the Geological and Mining Law, geological works projects and geological-engineering documentation are collected and archived by the geological administration bodies, and also by the National Geological Archive. The Construction Law and Eurocode 7 do not specify how to collect and archive the ground surveys. It is the documenter's and contracting authorities' as well as the reviewer's (e.g., Conservation Officer) responsibility to carefully secure and store research results and documentation for a specified period of time.

Water in a soil environment

The occurrence of water in the ground, apart from the so-called optimum moisture (moisture ensuring maximum compaction of non-cohesive soils and optimal consistency of cohesive soils) is an undesirable situation from a geotechnical point of view. Water makes it difficult to carry out earthworks (the need for drainage of excavations), reduces the physical and mechanical properties of soils and rocks, and its excess changes them completely (liquefaction, quicksand, karst phenomena). Water (usually mineralized to a varying degree) can aggressively affect the underground elements of buildings in ruin. But also water (moisture) deficit in certain conditions of cohesive soils (expansive soils) can cause large volume changes of the substrata (shrinkage), which often leads to damage or failure of a building object.

In the ground, water can be present in a more or less bonded (molecular) form and in a free form, which is subjected to the force of gravity and hydraulic drops. In the aeration zone (above the permanent groundwater level) water can be present in the form of water vapour.

The presence of ground moisture and free water in the ground is mainly associated with atmospheric precipitation. The supply of infiltration waters, which exceeds the molecular capacity of the ground causes water to move vertically down or along local hydraulic drops, determined by the level of groundwater or a layer of impermeable soils. Depending on the local arrangement of soil layers and their filtration properties (water permeability, effective porosity), the presence of suspended waters can be expected, forming an isolated local level supported by a layer of impermeable soils, above the permanent level of groundwater. Suspended water levels are usually seasonal and transient.

The level of groundwater, the so-called saturation zone is shaped by local ground, morphological, and hydrological conditions (watercourses and surface reservoirs determine the base of drainage). In river valleys, these waters usually occur relatively shallow, corresponding to the level of the river. According to the morphology, the depth of occurrence of groundwater increases in edge and upland zones (the aeration zone increases). These waters may locally have a water table whose pressure exceeds the atmospheric pressure, and in places of intersection of the aquifer with the surface, self-outflows in the form of springs are observed.

Water can occur in non-cohesive soils (gravels, sands), rocky sealed and cavernous soils. Effective porosity or fissure determines the capacity (abundance) and filtration parameters (water flows in the ground) and fluctuations of this level, which is particularly important in geotechnical considerations (water pressure, flow pressure, drainage).

Groundwater contains some amounts of dissolved gases (oxygen, carbon dioxide, nitrogen, methane) and ions: Na^+ , K^+ , Ca^{2+} , Mg^{2+} , Cl^- , SO_4^{2-} , HCO_3^- , NO_3^- . They come from precipitation, dissolution and ion exchange of the soil environment. In a large part they have their source in anthropogenic factors and then also come from some specific substances (phosphates, sulphates, petroleum substances). Mineralization of water causes the formation of pH (acidity) of pore and groundwater solutions. Depending on the mineralization, the aggressive impact of the water-soil environment can be dealt with by means of leaching (low total mineralization), carbonation (CO_2), or treatment with sulphates, magnesium, and ammonium.

Geodynamic processes shaping the geological-engineering conditions

The construction foundations are characterized by susceptibility to natural geological internal and external, ecological, and anthropogenic processes. These processes can have both destructive and building effects. For geotechnical practice, the most important are destructive processes, those that reduce the technical properties of rocks and soils: compressive strength, tensile strength, shear strength, increased deformability, displacement of substrate fragments (erosion, suffusion, subsidence, landslides) or even large volume fragments of the earth's crust (earthquakes). The course and extent of the destruction and loss of parameters depends both on the type of soil (soil type, geometry of soil layers, tectonics), water conditions (dynamics and chemistry) and the intensity of abiotic (geological, hydrological, climatic), ecological, and anthropogenic factors.

Weathering is a permanently ongoing process, although in our climatic conditions it is slow and hardly perceptible during one generation (for historic buildings, despite the lack of assessment of the initial state, these may already be changes of high significance for the stability and durability of the object). It is a process of physical and chemical (also biochemical) disintegration of rocks and soils under the influence of external factors. Physical factors of weathering are the thermal crumbling of the ground skeleton (changes in temperature, the effect of ice), swelling and shrinkage caused by moisture, erosion and suffusion caused by moving water, and mechanical (destructive) effect of plant roots. Chemical weathering processes related to the interaction of water (dissociation and hydrolysis, dissolution, crystallization, chemical suffusion), air (oxidation, reduction, carbonation), transformation of clay and biochemical minerals (humification, nitrification).

The dynamic processes associated with high-energy water flows, earthquakes, mass movements, mining damage or the vibrational impact of communication routes are more spectacular and visible often in the form of construction disasters.

The lateral erosion of watercourses and coastal erosion of reservoirs (abrasion) are of significant importance for existing construction objects as well as planned or designed ones (in the form of forecasts). Permanent or dynamic short-term impact of flowing water or waves causes undercutting of slopes, which lose their balance and undergo loosening, falling off or sliding changing the edge zone and posing a threat to building objects.

Runoffs, slides (landslides) and landfalls are types of surface mass movements, violent geodynamic processes related to violation of equilibrium as a result of the influence of internal geological factors (seismic), moisture (change of density and consistency of the ground) or anthropogenic (mining damage, undercutting slopes, filling of dam reservoirs). These processes are related to violation of slope stability.

- Runoffs occur after saturation of subsurface layers (especially weathered rocks and soils and alluvia in sloping deltas), changing cohesive or fine non-cohesive soils (dusts, silty sands) into semi-solid mass, which (due to loss of internal friction and cohesion) flows down even relatively mildly inclined slope. This process may also occur in soils less saturated with water but showing thixotropic properties (dusty clays, dusts) and subjected to seismic or anthropogenic vibrations. These processes also quite often take place under conditions of deep freezing of the ground and surface thawing in spring. The boundary between these two different centers (difference in consistency and strength) creates a slip surface.
- Slides (landslides in the narrower sense) have a complex genesis depending on the type of land, layout and geometry of the land, water conditions, morphology, external factors, including anthropogenic ones. Very often even a small change of one of these elements may lead to disturbance of the existing balance and displacement of soil masses. These processes usually progress quickly (a season or two), however, they can also last for years, allowing to take rescue actions.
- Landslides pose a threat to construction objects situated in edge zones (reduction of morphology and loosening of structure, failures and disasters of construction objects), on a slope (formation of landslide litter, displacement of construction objects), at the base (ground masses of landslide or displacement and dislocation of soil).
- Landfalls are processes more violent than landslides. They are related to peeling off a fragment of ground masses (rock) and moving down at a considerable speed. They are created under conditions of sharp slopes, with a high angle of inclination in natural (surface water) or artificial conditions of undercutting of slopes, as well as overloading of the edge part of the slope or detachment as a result of seismic interactions.

In the areas of occurrence of rocky carbonate soils (limestones, marbles, dolomites) as well as gypsum, the karst processes are a common phenomenon. Karst forms can create empty spaces in the ground, which weaken the rock mass and in their final development or under additional load they collapse, creating construction risks, most often of catastrophic character (sinkholes).

Forms of the surface karst constitute a very heterogeneous subsoil with a strong anisotropy of compressibility, from incompressible solid carbonate rocks to unconsolidated or loose soils filling pockets and karst formations.

Large differences in subsidence usually lead to emergency situations of a construction object. Building substrata of this type are very difficult to diagnose with classical research methods.

Test methods

Field studies form the basis for characterizing the conditions occurring in the object's base as well as the creation of a geological model and the separation of soil and rock layers and their geotechnical characteristics. The PN-EN 1997-2 standard recommends performing field tests at each stage of the substrate tests. This standard provides detailed requirements and methodological recommendations:

- geological-engineering mapping as a part of a field inspection,
- drilling with the sampling of land, rock, and groundwater,
- hydrogeological studies (statics and dynamics of aquifers),
- probing soil and rocks.

In addition, geodetic, remote sensing, geophysical, and environmental measurements should be made depending on the purpose, especially for historical buildings.

As part of good practices, the application of the PN-EN 1997-1 and PN-EN 1997-2 standards together with related documents should be made.

The purpose of geological-engineering mapping is the verification of archival materials, initial geomorphological characteristics of surface soils, identification of geodynamic processes and the state of construction (deformations, cracks, scratches, moisture), location of construction and mining damage areas, location of flooding areas and the range of high-waters (including 100- and 500-year water based on the maps of the Information System of the Country Protection), and verification of the feasibility of tests planned.

According to the PN-EN 1997-2 standard, the drilling method should be selected in accordance with the required types of samples to be taken, designed drilling depth, expected soil and water conditions, planned additional tests (laboratory, geophysical, probing), and drilling location. This standard recommends the use of drilling techniques included in the PN-EN ISO 22475-1 standard. For the description and characterization of soils, PN-EN 1997-2 standard recommends the use of the PN-EN ISO 14688 standard along with amendments and changes. In Poland, the PN-B-04448 standard is still used for soils diagnosis.

Hydrogeological studies in the scope of Eurocode 7 are made to determine the depth and nature of the occurrence of aquifers and directions of their flows, to determine the aggressiveness of waters, and to quantify the filtering parameters of soils and rocks. The results of these tests should be taken into account in geotechnical studies and design calculations.

The normalized and recommended probings of soils and rocks are included in the PN-EN 1997-2. Probing with a static conical probe of the CPT and CPTU type is particularly useful and recommended. The results of these surveys are used for: defining the geological boundaries, determining coarse soil compaction and the condition of fine-grained soils, detecting weakened zones, identifying the extent of the occurrence of organic soils, determining the susceptibility of the substrata to filter deformations, assessment of the stiffness and compressibility of the substrata and preliminary settlement of subsidence.

For in situ measurements of formability and preliminary prediction of subsidence of soil or soft rock, the PMT tests are applied in accordance with the PN-EN 1997-2. These tests are particularly useful for weak soils. With restrictions, the method can be used to pre-assess expansiveness and strength properties of the soil.

In geotechnical studies of historic objects' substrata, the WST screw probe can be used, which allows (in accordance with the PN-EN 1997-2) to determine the succession of layers, continuous profiling of soil strength, the degree of compaction of coarse soils, and the condition of fine-grained soils.

Less useful, due to the seismic impact, is the use of the DP dynamic probing and dilatometer methods in the vicinity of historical buildings. It is also connected with their low popularity in Poland and the lack of proven local correlations.

Geophysical surveys which, due to their non-invasive nature, seem to be appropriate for regions under conservation protection, according to the PN-EN 1997-2, among other information, can be used for general geological-engineering study programs or ground surveys. The surface geophysical, georadar, and gravimetric tests seem particularly useful. These methods allow for initial characterization of the substrata (layering, soil type, preliminary determination of strength properties, recording of discontinuities and voids in the ground, etc.). At the design stage, these methods allow to specify the geological structure model and properties of the separated layers obtained with other methods.

In large-scale geological-engineering studies, the remote sensing methods (satellite, aerial, and terrestrial) and photogrammetry (not included in Eurocode 7) are very useful. These methods are particularly useful for the analysis of landslides, ground subsidence, and other natural and anthropogenic processes that cause deformation of the terrain surface.

Geoengineering in maintaining historic buildings

The need and methods of eliminating the causes of destructive impacts of soil, water and ecological environment on a historic building and/or potential strengthening of its foundations are determined by conclusions resulting from the geological-engineering documentation and geotechnical findings, and also increasingly from the project's impact on the environment report (renovation, modernization, revalorization).

Very often it is enough to remove only the natural or anthropogenic causes, so that the process of destruction of the object may be slowed down or eliminated, however, the most common are also simultaneous actions to secure and strengthen the structure of the object. The solutions undertaken are unique for each location due to individual needs of the facility (facilities, complex) and the specificity of the soil and water substrata, and the environment surrounding the object.

Potential geoengineering activities that modify the cooperation of an object or a historical complex with the ground-water substrata are usually aimed at:

- increasing the load capacity
- reduction of settlements (as well as blinding)
- lowering groundwater level
- reducing hydraulic permeability
- eliminating or reducing harmful (geodynamic) phenomena
- eliminating natural discontinuities, voids and underground workings
- stabilization of slopes

Most of the goals presented can be achieved by solving power conditions and the flow of surface and groundwater as well as soil moisture regulation, which has a decisive influence on its mechanical parameters. The infiltration of rainwater and snowmelt is reduced or eliminated by sealing the surface or discharging them out of the direct impact range (by sewerage). Shallow aquifers are eliminated or lowered as part of surface or underground drainage (soil amelioration), their impact is reduced or cancelled, or their flows are changed by making directional sheet pilings (in the direction of inflow). Low effective levels or excessive moisture can be eliminated by means of sand drains (possibly by artificial drains, so-called the geodrens), electroosmosis or by phytomelioration (biocenotic solutions).

Strengthening and sealing of soil or rock substrata can be obtained by cementation and stabilization. The most commonly used are cement pastes and mortars as well as chemical additives (resins, water glass, silicate gels), also ground (clay) suspensions (where tightness is needed without increasing strength). The choice of the method and agent depends mainly on the porosity (presence of crevices), i.e., the type of a soil.

Liquidation of natural (e.g., karst) or anthropogenic (cellars, tunnels) voids in the ground substrata that threaten surface objects is performed by classic mining methods (filling, housing) or, in the case of smaller objects, by passive (soil) or active (cement, cement-sand) injections.

Stabilization of slopes is achieved by eliminating natural or excited geodynamic processes, the main causes of which are water (surface and ground) conditions, moisture conditions, and dynamic, most often anthropogenic, interactions. Elimination of the causes usually stabilizes or slows down landslides and slope movements, the effects are stabilized by biotechnical solutions (sowing, sodding, planting shrubs and trees) or geotechnical ones (geometry change, geotextiles, geogrids, gabions, retaining walls).

3.2. Examination of physical features of structural elements

Mechanical properties are the characteristic responses of material to applied stresses. Selection of mechanical tests for a particular application is based primarily on the experience that many lots of a particular grade of a material having properties falling within a certain range have performed satisfactorily in service. It can then be anticipated that new lots of this same material having the same mechanical properties will also perform satisfactorily in the same application.

Definitions

1. Strength - the ability of a material to resist applied forces.
2. Ductility - the ability of a material to undergo permanent shape change (plastic deformation) without rupturing.
3. Toughness - the ability of a material to absorb energy.
4. Tension test - simultaneously measures strength and ductility. There are several types of tensile machines and test specimens.
5. Modulus of elasticity (Young's modulus) - the proportionality constant between stress and strain - the slope of a plot of stress vs. strain within the elastic range - 30M psi for steel.
6. Yield Strength - 0.2% offset is normally specified for a tensile test since it is too difficult to measure the elastic limit accurately. The speed of loading affects yield strength but not tensile strength.
7. Yield point - the stress in a material at which a marked increase in strain occurs without an increase in stress.
8. Elongation in 1" or 2" is usually determined by fitting the fractured specimen back together and measuring the distance between scribe marks - % elongation increases with shorter gauge lengths.
9. Reduction of the area (RA) is the ratio of the minimum cross-section of a tensile specimen after a fracture to its original cross-section.
10. Shear stress is approximately half of the ultimate tensile strength for steel.
11. Hardness - resistance to deformation or penetration by a much harder indenter.

Mechanical Testing

Mechanical tests (as opposed to physical, electrical, or other types of tests) often involve the deformation or breakage of samples of material (called test specimens or test pieces). Note that test specimens are nothing more than specialized engineering components in which a known stress or strain state is applied and the material properties are inferred from the resulting mechanical response. For example, strength is nothing more than a stress "at which something happens", be it the onset of nonlinearity in the stress-strain response to yield strength, the maximum applied stress for ultimate tensile strength, or the stress at which the specimen actually breaks when reaching the limit of the fracture strength.

Design of a test specimen is not a trivial matter. However, the simplest test specimens are smooth and unnotched. More complex geometries can be used to produce conditions resembling those in actual engineering components. Notches (such as holes, grooves or slots) that have a definite radius may be machined in specimens. Sharp notches that produce behavior similar to cracks can also be used, in addition to actual cracks that are introduced in the specimen prior to testing.

Equipment used for mechanical testing ranges from simple, hand-actuated devices to complex, servo-hydraulic systems controlled through computer interfaces. Common configurations involve the use of a general purpose device called a universal testing machine. Modern test machines fall into two broad categories: electro- (or servo-) mechanical (often employing power screws) and servo-hydraulic (high-pressure hydraulic fluid in hydraulic cylinders). Digital, closed-loop control (of e.g., force, displacement, strain, etc.) along with computer interfaces and user-friendly software are common. Various types of sensors are used to monitor or control force (e.g., strain gauge-based "load" cells), displacement (e.g., linear variable differential transformers (LVDT's) for the stroke of the test machine), and strain (e.g. clip-on strain-gauge extensometers). In addition, controlled environments can also be applied through self-contained furnaces, vacuum chambers, or cryogenic apparatus. Depending on the information required, the universal test machine can be configured to provide control, feedback, and test conditions unique to that application.

Tension Test

The tension test is a commonly used test for determining "static" (actually quasi-static) properties of materials. Results of tension tests are tabulated in handbooks and, through the use of failure

theories, these data can be used to predict failure of parts subjected to more generalized stress states. Theoretically, this is a good test because of the apparent simplicity with which it can be performed and because the uniaxial loading condition results in a uniform stress distribution across the cross section of the test specimen.

Hardness

In the field of engineering, hardness is often defined as the resistance of a material to penetration. Methods to characterize hardness can be divided into three primary categories:

(1) Scratch Tests; (2) Rebound Tests; (3) Indentation Tests.

Scratch tests commonly involve comparative scratching of progressively harder materials. In mineralogy, the Mohs hardness scale is used as shown in Fig. 5.5. Diamond, the hardest material, is assigned a value of 10. Decreasing values are assigned to other minerals, down to 1 for the softest mineral, talc. Decimal fractions, such as 9.7 for tungsten carbide, are used for materials intermediate between the standard ones. Where a material lies on the Mohs scale is determined by a simple manual scratch test. If two materials are compared, the harder one is capable of scratching the softer one, but not vice versa. This allows materials to be ranked according to their hardness, and decimal values between the standard ones are assigned as a matter of judgment.

Rebound tests may employ techniques to assess the resilience of a material by measuring changes in its potential energy. For example, the Scleroscope hardness test employs a hammer with a rounded diamond tip. This hammer is dropped from a fixed height onto the surface of the material being tested. The hardness number is proportional to the height of rebound of the hammer with the scale for metals being set so that fully hardened (tempered) tool steel has a value of 100. A modified version is also used for polymers.

Indentation tests actually produce a permanent impression in the surface of the material. The force and size of the impression can be related to a quantity (hardness) which can be objectively related to the resistance of the material to permanent penetration. Because hardness is a function of the force and size of the impression, the pressure (and hence stress) used to create the impression can be related to both the yield and ultimate strengths of materials. Several different types of hardness tests have evolved over the years. These include macro hardness tests such as Brinell, Vickers, and Rockwell tests and microhardness tests such as Knoop and Tukon tests.

Torsion

The torsion test is another fundamental technique for obtaining the stress-strain relationship for a metal. Because the shear stress and shear strain are obtained directly in the torsion test, rather than tensile stress and tensile strain as in the tension test, many investigators actually prefer this test to the tension test. Since all deformation of ductile materials is by shear, the torsion test seems to be more fundamental of the two.

The torsion test is accomplished by simply clamping each end of a suitable specimen in a twisting machine that is able to measure the torque, T , applied to the specimen. Care must be used in gripping the specimen to avoid any bending. A device called a troptometer is used to measure angular deformation. This device consists of two collars which are clamped to the specimen at the desired gauge length. One collar is equipped with a pointer the other with a graduated scale, so the relative twist between the gauge marks can be determined. The troptometer is useful for measuring strains up to and slightly past the elastic limit. For larger plastic strains, complete revolutions of the collars are counted.

Impact

The static properties of materials and their mechanical behavior are very much functions of factors such as the heat treatment the material may have received as well as design factors such as stress concentrations. The behavior of a material is also dependent on the rate at which the load is applied. Polymeric materials and metals which show delayed yielding are most sensitive to load application rate. Low-carbon steel, for example, shows a considerable increase in yield

strength with increasing rate of strain. In addition, increased work hardening occurs at high-strain rates. This results in reduced local necking, hence, a greater overall material ductility occurs. A practical application of these effects is apparent in the fabrication of parts by high strain rate methods such as explosive forming. This method results in larger amounts of plastic deformation than conventional forming methods and, at the same time, imparts increased strength and dimensional stability to the part.

Fatigue Testing

If a material is subjected to repeated, or cyclic, stressing, it may eventually fail even though the maximum stress in any one stress cycle is considerably less than the fracture stress of the material, as determined by a tensile test. This type of failure is termed fatigue failure. Many components are subjected to alternating or fluctuating loading cycles during service, and failure by fatigue is a fairly common occurrence. The mechanism of fatigue in metals has been thoroughly investigated. When a metal is tested to determine its fatigue characteristics, the test conditions usually involve the application of an alternating stress cycle with a mean stress value of zero. The results are plotted in the form of an S-N curve, where S is the maximum stress in the cycle, and N is the number of cycles to the failure. Most types of steel show an S-N curve, with a very definite fatigue limit, or endurance strength. This means that if the maximum stress in the stress cycles is less than this fatigue limit, fatigue failure should never occur. Many non-ferrous materials show S-N curves with no definite fatigue limit. With these materials, it is only possible to design for a limited life, and a limit of 10⁶ or 10⁷ cycles is often used.

Creep Testing

The tensile test alone cannot predict the behavior of a structural material used at elevated temperatures. The strain induced in a typical metal bar loaded below its yield point at room temperature can be calculated from Hooke's law. This strain will not generally change with time under a fixed load. Repeating this experiment at a "high" temperature (T greater than one-third to one-half times the melting point on the Absolute temperature scale) produces dramatically different results. Creep can be defined as plastic (permanent) deformation occurring at high temperature under constant load over a long time period. After the initial elastic deformation, the primary stage is characterized by a decreasing strain rate. The relatively rapid increase in length induced during this early time period is the direct result of enhanced tensile strength.

In order to determine the technical condition, load-bearing capacity and strength of structural elements, a number of tests must be carried out. Based on them, it will be possible to determine the parameters determining the condition of the structure itself. The research is divided into two main groups: the indirect research and direct research.

The indirect tests are a type of research in which the determination of the desired parameters is based on the dependence of these parameters on other material parameters (e.g., determination of the compressive strength of material based on surface hardness tested by the sclerometric method).

The direct tests are tests in which the parameter sought is immediately determined (e.g., determination of the compressive strength by compression of a sample on a hydraulic press).

In addition, the tests are divided into in situ tests and laboratory tests.

The in situ tests are tests that are carried out on site and the result is known already at the time of the study.

The laboratory tests require the collection of a laboratory sample and determination of the parameters on a laboratory equipment.

In order to determine the bearing capacity of structural elements, computer models and numerical analyses are also used. The use of appropriate calculation algorithms gives the possibility to estimate the strength of structural elements. In order to make such a model, however, the parameters of the construction material must be known first.

3.2.1. Endoscopic examination

The inspection testing using an endoscopic camera is a completely non-destructive examination. The test may be quasi-destructive in the case of making a test hole into which the camera will be introduced.

The endoscopic examination consists in an inspection of hard to reach places. Depending on the endoscope used, the diameter of the camera is from 5 to even 30 mm. The camera is mounted at the end of a flexible cable. The cable length varies depending on the type of camera. Thanks to the considerable flexibility and length of the cable, it is possible to place the camera with backlight in both hard to reach places and the material structure. The whole picture from the camera appears on a real-time basis on the LCD display mounted on the handle. In most cameras, it is possible to record an image and take a picture. In order to increase the precision of tests, it is recommended to use cameras with high resolutions.

Thanks to the inspection tests, the following can be determined:

- what is located in hard-to-reach places that cannot be inspected without making an inspection hole first,
- system of partition layers - by making a test hole through the entire thickness of the partition, it is possible to record in real time changing layers of materials when inserting or removing a flexible cable with a camera,
- the type of materials used.
- material homogeneity,
- internal defects of materials - in the case of suspected damage to the internal structure of the material, after the test hole is made, it is possible to inspect the fragment in the structure.



Photo 5. The endoscopic camera

3.2.2. Ultrasonic examination

The basic device for performing these tests is the ultrasonic flaw detector - a type of device that is used to determine the properties by measuring the velocity of propagation of the ultrasonic wave in the material. Ultrasounds with frequencies of 24 kHz, 37 kHz, 54 kHz (as typical), 82 kHz, and 150 kHz are used during the tests.

The test is a specialist study. The technology of the study is varied and depends on the purpose of the study. Different test frequency and location of the test probes give the possibility to determine other parameters of the material tested.

Thanks to the ultrasonic testing, the following can be determined:

- density of the material tested,
- homogeneity of the partition tested,
- the geometry of the partition tested (determining the thickness of the partition with one-sided access),
- material defects (with their location and size).

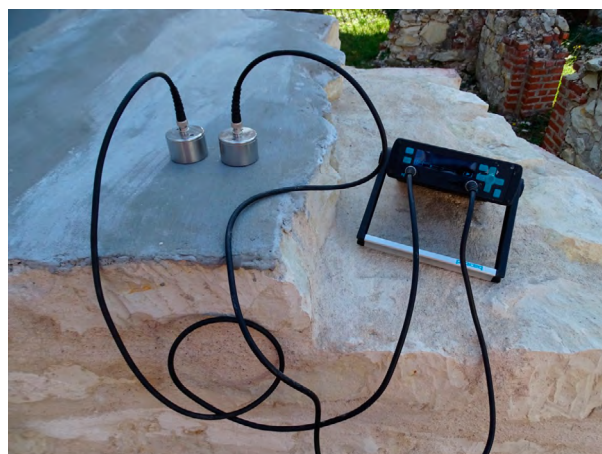

Photo 6. Ultrasonic testing equipment

3.2.3. Hammer test

Similarly to the ultrasonic test, the method is based on the phenomenon of propagation of acoustic waves in the elements tested, with the difference that they are excited in a mechanical way. The method of defect detecting is based on the echo method (waves reflected from defects in the material structure are registered and processed).

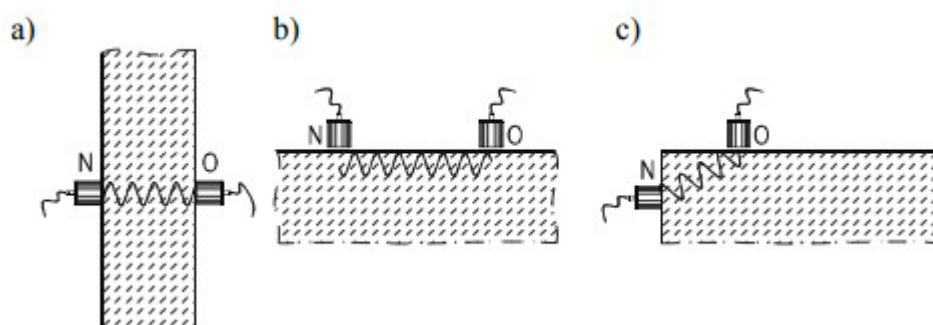

Figure 5. Scheme of performing measurements and distribution of probes⁸

Mechanical excitations are obtained by hitting the surface of the element tested with a small steel ball. The impact generates acoustic waves. These waves propagate within the material structure and are reflected by internal defects or its external surface. Displacements of the element caused by the return of reflected waves are recorded by a piezoelectric sensor in close proximity to the inductor. The obtained values of displacements as a function of time are transformed into the frequency spectrum and presented in the form of a graph. Multiple reflections of vibrations from the surface and defects lead to a vibration amplitude that can be identified in the frequency spectrum graph. This graph changes if there are any disturbances in the structure of the element and provide information about their location.

The test diagram is shown below. The waves reflected as a result of defects in the material are processed in computer software and then presented in the form of a vibration diagram and a spectrum of vibrations. These two charts are the basis for further analysis.

⁸ Drobiec Ł., Lokalizacja wad konstrukcji i stali zbrojeniowej - metody, Conference: XXI Ogólnopolska Konferencja Warsztat Pracy Projektanta Konstrukcji, 2006

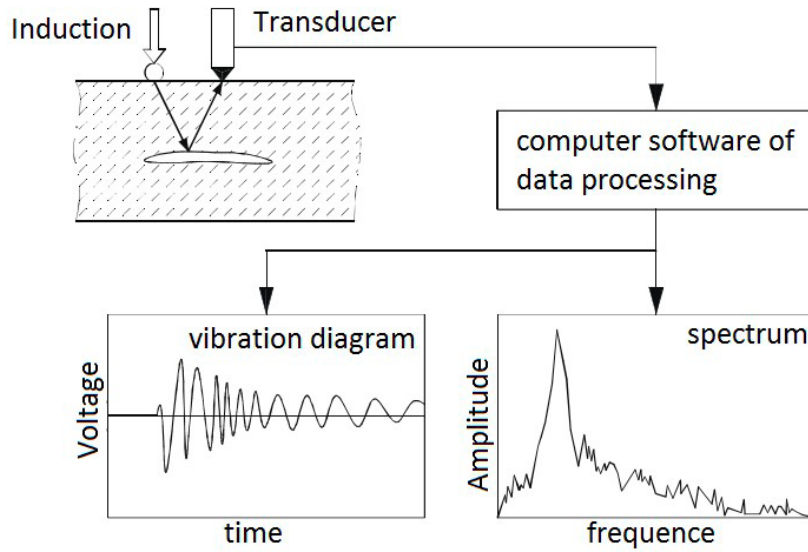

Figure 6. Scheme of the test⁹

Thanks to hammer tests, the following can be determined:

- cracks, delamination or air voids in the material,
- homogeneity of the partition tested,
- the geometry of the partition tested (determining the thickness of the partition with one-sided access),
- material defects (with their location and size).

3.2.4. Electromagnetic examination

The device is mainly intended for detecting reinforcement in reinforced concrete elements, but it is also used in monuments.



Photo 7. An instrument for the electromagnetic testing

In ruins of historical objects, an electromagnetic device is helpful in searching for fragments of old steel elements, which were often anchored in the wall (e.g., fittings, hinges, handles, fragments of gates and bars, etc.)

⁹ Drobiec Ł., Lokalizacja wad konstrukcji i stali zbrojeniowej - metody, Conference: XXI Ogólnopolska Konferencja Warsztat Pracy Projektanta Konstrukcji, 2006

3.2.5. Sclerometric examination

The Schmidt hammer test method is a sclerometric method that relies on the relationship between the surface hardness of a material and its compressive strength. In Poland, the test is carried out in accordance with PN-EN 12504-2:2013-03.

The sclerometer is mainly used in concrete constructions but it is also used in elements made of other materials.

The Schmidt hammer is a device that allows the assessment of the surface hardness of concrete based on the measurement of the jump from the surface, of the stem with a spring system, which strikes with a certain force. The measured value is the so-called number of reflection (L), which is read on the hammer scale.

There are 4 types of the Schmidt's hammers, differing in impact energy: N - medium (normal), L - light, M - heavy (massive), P - swinging.

Research procedure:

- place the hammer perpendicular to the surface to be tested and press slowly.
- pressure causes the shock mass to regress and to pull the shock spring. (Withdrawal of the mass causes an automatic release and the impact on the spindle. After the impact, the mass jumps on a certain length, which is recorded with the help of the indicator).
- reading on the scale - the number of reflections L.
- the rules of measurement are identical for all types of hammers.

Number of test sites:

- perform the test at least in 12 places in one element
- at least 5 readings should be made at the test site.

Places where results can be unreliable:

- at a distance of less than 3-4 cm from the edge of the element,
- a corroded surface,
- elements with low stiffness,
- moistened surfaces (understated readings),

Interpretation of the results

Based on the research, the value of the so-called the number of reflection L is obtained, which is read directly from the hammer scale. Then, based on the number of reflection and regression curves determined individually for each material, it is possible to estimate the compressive strength of a given element.

Formula for determination of the compressive strength R:

$$R = aL^2 + bL + c$$

where:

R - compressive strength [MPa],

L - the number of reflections based on the arithmetic mean of 12 test sites,

a, *b*, *c* - parameters determined on the basis of a regression curve, developed individually and experimentally for each material

Thanks to the sclerometric tests, the following can be determined:

- surface hardness of the element tested,
- compressive and tensile strength based on its relationship with the surface hardness,
- homogeneity of the elements tested,
- adhesion of finishing layers (adhesion of plasters to a construction element),
- occurrence of local defects, discontinuities, or disturbances in the structure of the element.



Photo 8. Sclerometric test

3.2.6. Peel strength test (pull-off)

In existing facilities, a common phenomenon is the loosening of the finishing layers. This can indicate either damage to the finishing layer, or damage to the substratum or the contact layer. In order to determine the adhesion parameter, the pull-off peel strength test is performed. The strength of the substratum itself is important when designing replacement, new, or repairing layers.

The purpose of the test is to determine the adhesion of the finishing layers to the substratum or the peel strength of the substratum itself. On the basis of the peel strength results, it is possible to estimate other material parameters such as e.g., compressive strength (using the test as an intermediate test).

The peel strength test is described in the *PN-EN 1542:2000 standard - Products and systems for the protection and repair of concrete structures - Test methods - Measurement of bond strength by pull-off* and *PN-EN 1015-12:2016-08. Methods of test for mortar for masonry - Part 12: Determination of adhesive strength of hardened rendering and plastering mortars on substrates*. Due to the atypical nature of the research conducted on a historic building, both these standards are used. The PN-EN 1542:2000 standard is recommended for using the adhesion parameter of the substratum itself, while PN-EN 1015-12:2016-08 for testing the adhesion of plaster to the substratum.

The test methodology in both standards is very similar.

Before starting the peel strength test, the substratum must be prepared accordingly. The first step during the preparation of the substrate should be its cleaning, desquamation, and grinding in the case of significant irregularities. If the adhesion parameter of the substrate itself or a layer other than the surface layer is examined, the material should be exposed and the preparatory work should be carried out on it.

After this preparation, the layer should be cut with a diamond crown by cutting the test piece with an internal diameter of the crown equal to 50 mm. The depth of incision is very important during the test itself. In the case of finishing layers, it is recommended to cut through the entire thickness of the layer (in the case of plasters according to PN-EN 1015-12: 2016-08, 2 mm deep cut is allowed). In the case of structural layers, a cut of not less than 10 mm in depth is recommended. The depth of the incision may affect the results of the measurement, so to compare the results from different samples the test should be prepared in the same way.

Then the discs with dimensions compliant with the standards should be attached to the substrate tested with an epoxy resin. It is necessary to avoid spreading the resin outside the test area as it can disturb the measurement results. The resin must have a tensile strength greater than the expected peel resistance of the substrate. Resin hardening time, application method, and hardening conditions should be as recommended by the manufacturer.

After hardening of the glue on a steel disc in a place designed for it, a steel spindle should be placed. Then, according to the recommendations of the standards, the test should be performed with a force increasing by 10 N every 1 second. The test is carried out until the sample is detached from the base.



Photo 9. Photo of a peel strength test.



Photo 10. A picture of the disc and the test site.

Determination of the adhesion parameter

Mortar f_h adhesion expressed in MPa is calculated using the formula:

$$f_h = \frac{4F_h}{\pi D^2}$$

where

f_h - adhesion of the test sample in MPa (megapascals)

F_h - load on destruction in N (Newtons)

D - sample diameter in mm (millimeters)

Accuracy of calculation up to 0.1 MPa.

Then, the mean adhesion should be determined from at least three reliable test results (with standard destruction). If there are numerous non-standard destructions, the test should be repeated until the intended number of results is obtained.

Determination of the type of sample destruction

The type of sample destruction should be determined visually. The following types of destruction are possible:

- A - destruction in the base layer
- B - destruction in the test layer
- Y - destruction in the adhesive layer

A/Y or B/Y means damage between the substrate and the adhesive layer or the test layer and the adhesive one. A/Z means the destruction between the adhesive layer and the disc.

Test report

The test report should contain the following information:

- date and the place of the test collection
- identification data regarding the material tested (type, layer thickness)
- methods for preparing the substrate
- diameter, thickness, and type of material from which the discs were made
- type of glue used in the test
- characteristics of the test device with information on the manufacturer, type, maximum peel force, and measuring range
- load on destruction and average diameter for each test site
- results of individual adhesion tests and average values
- type of destruction at each study site
- any irregularities and other comments noted during the test

Dyna equipment by Proceq. The study used metal discs with a diameter of 50mm.

Thanks to pull-off research, we can determine, among others,:

- adhesion between materials (e.g. plasters and masonry walls),
- tensile strength of the substratum,
- estimation of compressive strength and tensile strength of the element (based on the relation between peel strength and other physical parameters),
- occurrence of local defects in the structure of the element.

3.2.7. Thermovision examination

Thermovision is a diagnostic method based on the detection of radiation in the infrared spectrum and the conversion of this radiation into a visible image. Thanks to this, the temperature distribution and its values on the external surface of the object tested can be observed and evaluated. The image is created by the camera registering the radiation emitted by the object observed, and then processing it into a colored temperature map. The resulting map is then interpreted graphically, where each temperature value is assigned a different color or shade of gray, so that the thermal image of the object is seen in the viewfinder or in the computer.

In buildings in ruin, the thermal imaging camera finds its application for recognizing various elements. Due to the phenomenon of thermal accumulation, materials with different densities will obtain different temperatures. There may be a situation, in which the materials have reached a temperature balance with the surroundings and will have the same surface temperature, regardless of their density. Then the test should be extended to active thermovision. Active thermovision consists in temporarily heating or cooling the examined part of the element. Due to differences in the physical construction of materials, they will heat or cool at different rates. By observing in real time the temperature changes of the examined fragment caused by the external factor of elevated or reduced temperature, it is possible to identify the elements. When performing active thermovision, the influence of the thermal shock on the elements tested should be taken into account. The test temperature should be chosen in such a way as not to damage the object tested.



Photo 11. Thermal camera during a test



Photo 12. Non-destructive testing methods for building structures of Janowiec Castle

Advantages of testing with a thermal imaging camera:

- infrared thermography is a non-destructive and non-contact research method,
- radiation is safe for people and the environment,
- a wide range of applications and a wide range of temperatures measured,
- the measurement is made in real time,
- it allows for effective measurement of the temperatures on the surface of hard-to-reach objects.

Limitations during the test:

- the high cost of the apparatus (in the case of active thermal imaging, the additional cost of the thermal stimulation system),
- there must be no obstacles between the infrared camera and the test surface,
- the phenomena of convection, radiation, and heat conduction distort the measurement,
- the difficulty of obtaining homogeneous heating of a large surface when using active infrared thermography,
- when using active thermography, defects can only be detected in the surface layer of the material.

Thanks to thermal imaging, the following can be detected:

- material differentiation hidden under the face layers,
- defects, air voids, discontinuities in the material,
- presence of moisture,

3.2.8. Testing by pressure cushions

The test with the use of the pressure cushions is one of the basic methods of evaluating existing masonry structures in the countries of the Western, South Europe, and in the United States.

Pressure cushions are used for measurements of two types:

- stress measurement in the masonry with a single pressure cushion,
- measuring the deformability of the wall and possibly its strength by means of two pressure cushions.

The method of determining stresses in the masonry by means of pressure cushions is very simple. The first step is to properly arrange the control points and measure the distance between them (with an accuracy of 0.001mm). Next, a groove in which the pressure cushion is placed should be made (by cutting or notching) between the measuring points. The pressure cushion is made of a metal sheet and its shape depends on the shape of the groove made. Next, the cushion is filled with a liquid and the stresses caused by filling the cushion and increasing its volume in the masonry are monitored on a current basis using a manometer. Measurements between control points are performed on a regular basis. The value of the manometer must be read when the values of the distance from before the groove was made are equalized. After proper reduction of the value depending on the shape of the cushion and the pressure surface of this cushion, the value obtained is the value of stresses in the masonry. Based on the analysis of the technical literature, the measurement error was estimated at no more than 33%.

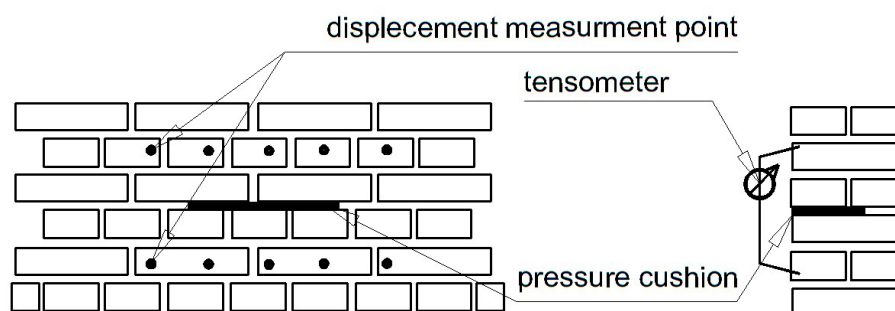

Figure 7. Stress measurement in the masonry with a single pressure cushion

On the basis of measurements, the stresses in the wall are determined by means of the formula:

$$f_m = Q K_m K_a$$

where:

Q - pressure in the pressure cushion,

K_m - calibration constant of the pressure cushions,

K_a - the ratio of the surface of the pressure cushion to the surface of the hole in which it was placed

Measuring the deformability of the wall consists in making two grooves and fixing cushions in them. control points between the grooves should be marked and distance measurements on them should be taken. Determination of deformability of the wall consists in describing the relationship of stress increase to strain increase (Young's modulus) in the masonry structure.

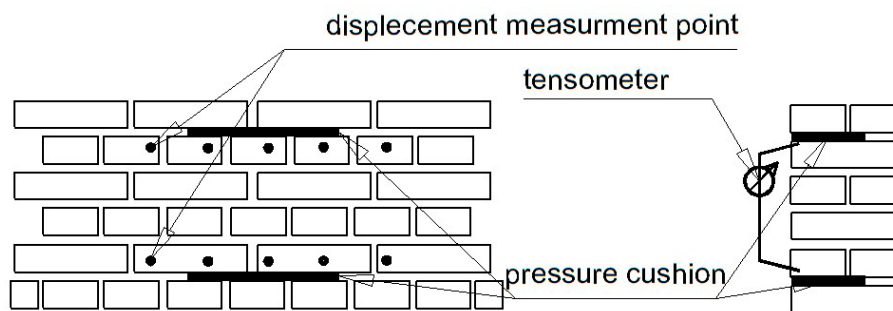

Figure 8. Measuring the deformability of the wall and possibly its strength by means of two pressure cushions

In order to obtain the result of the compressive strength of the wall, it is necessary to put pressure in the cushions to cause local destruction of the masonry structure. The destructive pressure will be the limit strength of the masonry structure. Destruction is not reversible, and the test becomes a destructive test.

$$E_t = \frac{\Delta f_m}{\Delta \varepsilon_m}$$

where:

Δf_m - measured stress increase,

$\Delta \varepsilon_m$ - measured strain increase

Thanks to pressure cushions, the following can be determined:

- stresses in the wall,
- compressive strength of the wall,,
- basic wall parameters such as the Young's modulus or Poisson's ratio.

3.2.9. Computer analysis

In order to determine the bearing capacity of structural elements, in addition to material testing, computer analyses are also performed. Computer analyses, in the case of monuments, are very complicated and are often erroneous. This is due, among other things, to the material inhomogeneity of the partitions and the inability to determine the material parameters necessary for the analysis (compressive strength, tensile strength, modulus of elasticity, etc.). On the basis of such analyses it is possible to obtain stresses in the structure and to estimate its bearing capacity. In historic buildings, computer analyses are made for wall elements and the ground. The subsoil is the basis for the structure and in the case of objects only this is analyzed. The analysis of phenomena occurring in soils is a very broad and complicated concept and is performed only in special cases.

Analyses of masonry structures are performed more often. Masonry structures are composed of masonry material and mortar. This means that for the analysis of the structure the wall is treated as a composite. Depending on the complexity of the partition and its diversity, the final results are subjected to various errors.

In the case of a structure analysis by computer methods, the FEM (Finite Element Method) method is most commonly used. This method can be distinguished by two general calculation approaches for the masonry model - one based on separate modeling of individual components, the other as a wall model made of a composite (one material with given parameters, without specifying masonry material and mortar).

The first method, also called the micro-modeling or heterogeneous modeling, requires a much more detailed modeling than the other method. It is necessary to determine the Young's modulus (modulus of longitudinal elasticity), the Poisson's coefficient and non-linear characteristics of wall elements and mortar. In addition, the contact zone should be appropriately modeled, which will reflect the joining of the masonry element and the mortar. The micro-modeling is applicable only in the case of small fragments of masonry.

A other method, called the macro-modeling or homogeneous modeling, is recommended for modeling of the whole structure. It is a simplified method and there is no specification of masonry and mortar here. These types of solutions accelerate and simplify the analysis, however, significantly affect its detail.

It should be remembered that when performing computer analyses, the optimal models should be selected to be effective - a sufficient analysis result should be obtained in the shortest possible time. Below, there are examples of the analysis of the masonry structure of an existing object using the first method - the heterogeneous one.

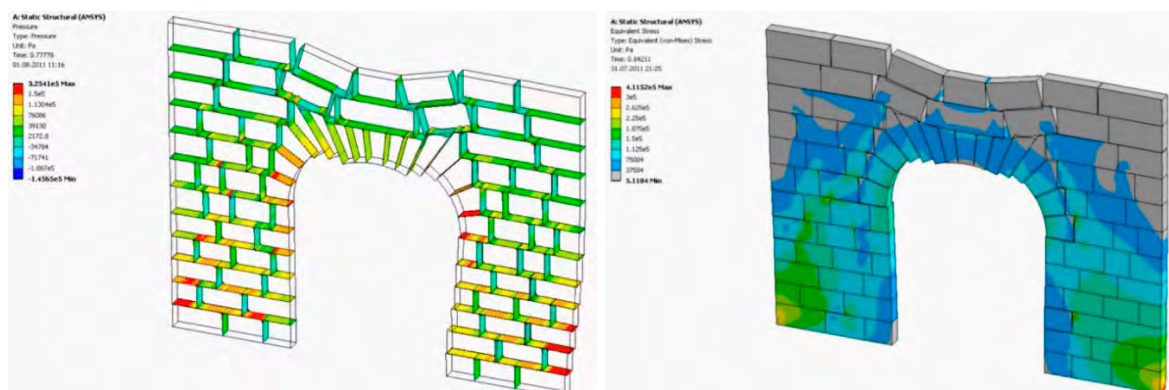

Figure 9. View of stresses in a wall element and joints¹⁰

3.3. Moisture testing by indirect methods

The direct (laboratory) measurement is considered as the only reliable way to measure moisture. Laboratory moisture tests, however, have a number of limitations associated primarily with: research costs, time of obtaining results and the necessity of often quite deep interference in the partition or the element being tested. In many cases, it is difficult or impossible to take material for tests (studies in historical buildings, structural elements of roof trusses and ceilings). An alternative in such situations are measurements using indirect methods of moisture testing.

The indirect measurement is a measurement whose result is obtained on the basis of a direct measurement of other values, based on the known relationship between these values and the value measured. The division of indirect methods for testing the moisture content of materials is as follows:

- Chemical methods: carbide, Karl-Fisher's, indicator papers

¹⁰ <https://i.ytimg.com/vi/sMpNE9L2reY/maxresdefault.jpg>, 20.07.2018

- Physical methods: electrical (microwave, dielectric, resistance), non-electrical (extraction, nuclear, nuclear magnetic resonance, based on the equilibrium of partial vapor pressure, based on the measurement of thermal properties).

Tab. 2nd The division of moisture determination methods.

Type of method	The name of the method	Parameter measured
Chemical methods	indicator method	discoloration of the indicator paper due to moisture of the material
	carbide method (CM)	pressure of acetylene (formed by the reaction of carbide with water) in a hermetic chamber
Physical methods, electrical	electrofusion method	change of electrical resistance caused by change of moisture
	microwave method	suppression of microwaves passing through moist material
	dielectric method	change of the dielectric constant of the material as a result of moisture change
Physical methods, nuclear	neutron method	the number of neutrons slowed down due to a collision with hydrogen atoms
	method of the γ radiation screening	change in the γ radiation intensity after passing through the material tested

In situ, only a few methods are actually used. The most important ones are: dielectric, resistance, microwave, and carbide. The other methods are more theoretical than practical.

3.3.1. Capacitive - dielectric method

The dielectric method consists in using the phenomena of changing the electrical capacity of the material along with the change of the moisture content. There is a connection between the humidity of the material and its dielectric constant. The dielectric constant E is a multiple of the capacitor's electrical capacity, in which the dielectric is the body determined in place of air or vacuum. The dielectric constant of water is the largest of all materials in construction, it is $E = 81$. The dielectric constant of moist solid and liquid substances reaches the value of 2-7. Due to the large difference between the dielectric constant of water and anhydrous substances, the proportionality between the moisture content of materials and their dielectric constant can be assumed. The advantage of this method is the lack of invasiveness as well as the ease and speed of measurement. The biggest drawback is the small measurement depth usually up to several tenths of millimeters and the measurement error when testing highly saline materials. Due to the high uncertainty of the result, these devices are often treated as so-called "moisture seekers".



Photo 13. The LB-796 dielectric moisture meter.



Photo 14. The LB-796 dielectric moisture meter.

Despite the aforementioned limitations, the dielectric measurements are a very good solution in investigating the moisture status of objects in ruin. Due to their large size, laboratory moisture tests are difficult to carry out. Determination of the moisture status requires sampling at 2-3 heights every few meters. This means that a very large number of wells should be drilled that would violate the historical structure.

The use of dielectric meters allows for very quick and non-invasive execution of hundreds of measurements. On their basis, it is possible to create moisture maps, graphically illustrating the moisture status of large masonry surfaces. The map also allows for a conscious choice of places from which material for laboratory tests can be collected. This significantly limits the costs and scope of interference in the historic structure.

3.3.2. The resistance method

The basis for the operation of the electrofusion method is the examination of the electric field change produced in an artificial way in the medium by a system of electrodes supplied with direct current. The measurement is based on the measurement of the resistance of moist material between the system of two electrodes. Resistance meters are definitely more often used to measure the moisture of wood and wood-based materials. Depending on the properties of the material being tested and the nature of the measurements, the meter settings are changed. The resistance method is considered as destructive, as the measurement consists in inserting thin measuring needles, which leave small holes in the material tested.



Photo 15. The Protimeter Timbermaster Moisture Meter hygrometer.



Photo 16. The LB-796RM resistive probe.

Tab. 3rd An example of a table with the results of measurements of the roof structure moisture using the resistance method. Elements with acceptable humidity are marked in lighter colors, elements with increased humidity are marked in darker ones.

Designation	Moisture [%]
< designation of the measuring place >	<moisture value>
...	...
...	...

When testing the walls of historical buildings, the resistance method is used sporadically. This is due to the fact that high salinity of the materials tested makes it unreliable and inaccurate. With a large number of ions in the water contained in walls, resistance meters give values that are overstated, often several times in relation to the actual value. Definitely more often the resistance measurement is used to study wood. The range of interference is so small that it can be successfully used even in the study of elements with very high hardness.

3.3.3. The microwave method

This method is included in a non-contact moisture measurement. It consists in measuring the phase shift and the degree of electromagnetic wave attenuation in the material tested. On the basis of the dependence of these parameters on the mass of water in the sample, the moisture content can be determined. If the thickness of the sample and the wavelength are constant, the moisture depends only on the dielectric properties of the material.

The moisture measurement is based on contacting the probe with the material tested and reading the result. The microwave method for measuring the moisture content of materials is far less popular than capacitive and resistance measurements. This is mainly due to the much higher price of the equipment and the clearly shorter experience of its use in material research. The problem is also the lack of humidity reading expressed in %. Most often, the meters display results in non-appointed units, which makes it difficult to interpret the values obtained.



Photo 17. The TROTEC T610 hygrometer



Photo 18. Moisture measurement by the microwave method

3.3.4. The chemical method

One of the most popular methods of humidity testing by indirect methods is the chemical method - the carbide method. The sample is taken from the partition most often by drilling. Next, a specific weight of the material and calcium carbide is introduced into a sealed steel vessel equipped with a pressure gauge. Measurement kits with ampoules containing ready-made calcium carbide samples are also available. When shaking the vessel, the ampoule is broken and the contents are mixed. The reaction: $\text{CaC}_2 + 2\text{H}_2\text{O} \Rightarrow \text{C}_2\text{H}_2 + \text{Ca(OH)}_2$ produces acetylene and increases the pressure in the cylinder, whose value is determined after a certain time. Moisture of the sample corresponding to the pressure created can be read from the table attached to the device - in an older type device. In newer devices, the sample mass of the material tested, the measuring range of the manometer, and the dimensions of the measuring chamber can be selected so that the manometer is scaled directly in percentage of relative moisture.

The material should be collected with a hammer or chisel. Electrical tools must not be used, in order to avoid drying the sample while obtaining it. The material should be taken in the most moist place. The hole should cover approximately 2/3 of the thickness, and the top layer should be omitted. The material so obtained should be crushed so that the maximum material size is 2mm. All the operations before the cylinder is closed are carried out as soon as possible to prevent a change in humidity of the material collected. The mass of the sample needed for the test depends on the type of hygrometer and the moisture content of the material, and is within 10g - 50g.

The measurement accuracy is around $\pm 3\%$. The main reason for the inconsistency of the results with the gravimetric tests is that the carbide does not react with chemically bound water. Differences are very noticeable when testing highly saline materials. Despite the relatively large measurement error, the carbide test is the most accurate in the group of indirect methods. A significant disadvantage remains the necessity to interfere with the structure of the elements examined.



Photo 19. The WK-1 hygrometer



Photo 20. Investigation of moisture by the carbide method, reading of the acetylene pressure in the tank

Tab. 4th The results of comparative tests of the carbide meter in relation to results obtained using the laboratory method.

Ceramic brick				
SampleNo.	Laboratory [%]	Chemical [%]	Difference [%]	Error [%]
1	2.65	1.42	1.23	46.4
2	5.62	4.6	1.02	18.1
3	8.91	7.76	1.15	12.9
4	11.98	8.81	3.17	26.4

Ceramic brick				
SampleNo.	Laboratory [%]	Chemical [%]	Difference [%]	Error [%]
5	13.26	10.74	2.52	19.0
6	14.91	11.36	3.55	23.8
7	16.97	14.94	2.03	11.9
8	18.98	15.74	3.24	17.1

3.4. Macroscopic research - “outcrops”

Outcrops are non-destructive. Thanks to the outcrops, it is possible to identify materials and determine their technical condition. In order to make outcrops, the materials covering the element tested should be removed. The top layers (plaster) are usually removed: less frequently deep layers (wells) are removed but then the damage has a minimized surface area. Always before removing the top layers in order to reveal the structure, make sure that these layers are not subject to the conservation protection.

Outcrops should be documented by drawing and photography.

The following types of outcrops are distinguished:

- point (holes)
- linear (cutting grooves, linear edging)
- surface (hacking off, exposures, excavations)

Point outcrops

Point outcrops are made in the form of boreholes. The boreholes are intended to obtain information about: material homogeneity (full depth or not full depth), material type (incomplete depth), continuity of the partition (full depth), and thickness of the partition (full depth).

Performing the test:

- the test is performed using a driller with the right type of a drill (for concrete, brick, wood, steel) and of appropriate length,
- the cuttings are observed (color, type, humidity) during drilling. This will allow to specify the material of the element that is being examined,
- the drilling is performed with a constant force, analyzing its magnitude which is necessary to drill through individual parts of material (this will allow to roughly evaluate the quality of the material),
- the irregular nature of the drill’s work (if it occurs) should be noted, including the actual depth of the borehole (this will allow to determine approximately the homogeneity of the material, detect voids or change of a material)

Linear outcrops

Linear outcrops are designed to examine repeating elements (e.g., brick dimensions under the plaster) or they are of a pilot nature before making surface or other outcrops (e.g., cutting a groove until it encounters a supporting beam).

Performing the test

The test is performed using a hammer drill with the appropriate tip (chisel) or by hand. It should be preceded by manual overcutting of the material tested in order to limit the damage zone.

Surface outcrops

Surface outcrops are aimed at obtaining information about repeating elements, or the relationship between a greater number of construction elements. As an example, an examination of the method of wall binding and the arrangement of bricks in them can be given.

This type of outcrops is particularly valuable, the amount of information possible to obtain is very extensive. Such outcrops allow to assess: the technical condition of the structure (behavior), type of material, manufacturing technology, originality or secondary nature of the solution, age, and order of formation.

In historical buildings, surface outcrops made for walls and ceilings are most commonly found.

During the construction of the outcrops of ceilings, attention should be paid not only to construction materials, the method of support on walls or other structural elements, but also to non-structural materials (e.g., pugging), which may also indicate the originality and age of the structure.

In the case of walls, the surface outcrops most often (this is the most reasonable) should be made in the corners of the walls and above openings. An outcrop over a hole will allow to determine the material, technology, and type of lintels and the way the ceilings are supported. The outcrop in the corner will allow two walls to be tested simultaneously with a slightly larger test area, and will also allow an analysis of how these walls are connected.

Performing the test:

- marking the place of examination
- cutting the outline of the planned range of the outcrop
- removing the plaster layers
- clearing out of the outcrop (making the bond visible)
- making additional cut at the interface of walls (penetration)

Conservation outcrops for mortars and painting layers

Investigations of mortars and painting layers are carried out by conservators-restorers of works of art. They are aimed at recognizing the decor and historical building materials in terms of their construction and components used, as well as texture, colors, stratification analysis, state of preservation, damage and its causes. The goal of most studies is to prepare guidelines for conservation projects.

In-situ testing of the decor usually starts with a detailed inspection of the object. At the beginning, the layers visible in the already damaged parts of the monument are analyzed, and then the bottom layers are exposed in places deemed as optimal for the occurrence of painting layers. Optimal points and test spaces of rebuilt masonry structures and secondary painting decor do not always overlap.

A stratigraphic research on a historic building is aimed at establishing and defining the chronology of the existing technological and historical layers, such as the basic building material, mortars, foundations, and painting layers. Such data provide knowledge about the original character of the object, which in the case of architectural research expands knowledge about the original technology of construction, the original color of the facade and its architectural detail. The arrangement of historical layers also tells a lot about the history of the object studied, such as the quantity and quality of renovations, the occurrence of primary elements (original, originating from the time of the monument's creation) and secondary ones (as a result of subsequent interference in its form or function). The obtained data, in addition to information about the monument such as the history of the object, iconographic material, relations of residents and owners, enable to perform a detailed conservation analysis of a historical building.

Particular attention should be paid to the places where polychromes are most often made, places that are difficult to access, where there may be traces of the original color scheme and the places of planned studies of the structure of the brick building. The number of the last ones, due to the deep interference in the structure of the building, is limited to the necessary minimum.

The basic means of understanding the stratigraphy of paint layers and plasters are the so-called

outcrops and probes. The outcrops is a method that allows to reveal successive layers (masonry, plaster, or layer of paint) in order to determine the range of its occurrence (strip and cross outcrops). The probes are the result of unveiling subsequent layers lying on each other (stepped probes, dial indicators probes). Regardless of the nomenclature, the subject of research on masonry structures and architectural decor is both the stratigraphic system and the surface range of the layers. With time, formal groups of outcrops and probes were distinguished i.e: point, strip, serial, cross, irregular outcrops, step probes and dial indicator probes..

The developed standardized mesh system of cross probes and cross-strip outcrops. Drawn on the walls horizontal and vertical strips with a width of 10 cm at a distance of 1 m and in their area outcrops are performed by removing the outer layer of plaster or painting layer. In the course of making outcrops and probes, subsequent layers are removed mechanically, using tools adapted to the type and size of the layers. Plasters are usually broken using various types of hammers and chisels. Delicate paint layers are removed using appropriate knives and scalpels. Additional needles are used to remove the remnants of secondary layers from the textures of the underlying layers.



Photo 21. *Strip outcrop with probes revealing bottom layers of painting.*

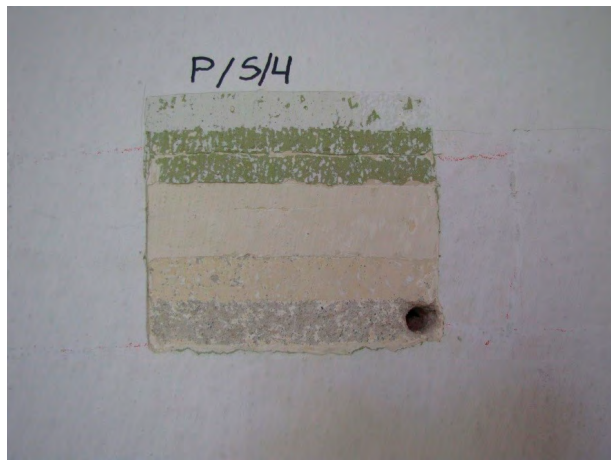

Photo 22. *Stepped probe showing the arrangement of layers of plasters and paintings on the wall.*

In situ studies of mortars and paints provide, first of all, knowledge about the quantity and quality of repairs and, what is important, determine which of the discovered layers are precious - they have the character of polychrome, stucco, etc., and which were less valuable - renovation of the room by ordinary paint. Only further specialist research of individual layers will provide more accurate knowledge about them.

It should be borne in mind that the test will not indicate the exact date of creation of each layer. Such information is available on the first and last layer, however, these data mostly come from historical research and interviews with residents. The usual information about the date of creation is approximate.

During the unveiling of individual layers of plasters and paintings, these surfaces are observed with the naked eye as well as with the use of a magnifying glasses. Photographic documentation is made, obtained in various bands of electromagnetic radiation (UV, VIS, IR). The analyses allow to indicate the places of sampling for laboratory tests (IR, TAR, RTG). From the analysis of samples, the following information can be obtained: the technology, the technique of making individual layers, their condition and causes of damage as well as identification of layering resulting from the impact of the natural environment. Making outcrops and probes is an invasive test, it creates a risk of damage to the exposed layers, it is labor-intensive and difficult to apply if there is delamination of plasters and paintings. Nowadays, thermovision and radar methods are increasingly used in research. The radar method makes it possible to visualize the contours of bricked up windows and doors, cracks, empty spaces in the walls, splices in plasters, and renderings. Synchronous

thermography locates the dissolution of plasters and painting layers, which occur at various depths it reveals the outline of the composition of wall paintings covered by layers of whitewash or overcoat. The radar method allows for obtaining information about the internal structures of the walls and the degree of their coherence. It allows for identification of places with heterogeneous materials, thickness measurements of walls, mortars, plasters, bricked up window and door openings.

After analyzing the layer layout, a stratigraphic image can be created, which is presented in the form of a table. In the table, information about particular layers is presented and they are assigned to the period which they come from.

Tab. 5th Collective stratigraphy of a wall painting.

Technological layers	Graphic designation	Chronological layers	Dating	Layer identification	Thickness of layers
<Arabic numerals are used to order technological layers starting from the face of the object.>	<When making a stratigraphic drawing, graphic symbols displaying the technological layers are used. The length of individual technological layers in the drawing and their spacers show the overlapping of these layers, illustrating the approximate extent of their surface on the object. >	<Roman numerals are used to order the chronological layers starting from the ground. stratification numbering prior to maintenance illustrates the stratification of the object in subsequent historical stages. >	<The chronological layers should be dated, the date should be placed next to the next layer number. This allows to recognize the epochs of style and refines the time of creation. >	<Each technological layer should be briefly described, e.g., limestone, whitewash, blue oil paint.>	<When describing thick layers (e.g., mortar), an average thickness in millimeters should be given.>

3.5. Biological corrosion and vegetation

There are a number of factors responsible for the degradation processes of objects protected in the form of a permanent ruin. In most cases, these processes are caused by atmospheric factors (water, sun, frost, wind, etc.), factors associated with changes in groundwater conditions, changes in the statics of objects or human activity. A separate group are living organisms inhabiting and overgrowing objects.

The group of organisms responsible for the destruction of ruins includes mainly annual and perennial green plants, trees and shrubs, house fungi, molds, algae, lichens, mosses, and insects¹¹. In the case of objects left in a form of the permanent ruin, the negative effect of house fungi and insects is of marginal significance. All of the others listed to a lesser or greater extent affect the degradation processes of the ruins.

These organisms are responsible for the phenomenon of biological corrosion, also called the

¹¹ Eklund J. A., Young M. E., Biological Growth on Masonry: Identification & Understanding. Inform. Information of historic building owners. Published by Historic Scotland, January 2013, Kozarski P., Molski P., Zagospodarowanie i konserwacja zabytkowych budowli. Towarzystwo Przyjaciół Fortyfikacji, Fortyfikacje tom XIV, Warszawa 2001

biodeterioration, understood as various forms of destruction of building elements caused by the action of living organisms, so-called the biological pests. There is a distinction between chemical assimilatory and dissimilatory biological corrosion. The former is the most common form of this process and takes place when the material is degraded because of its nutritional value. The latter, the chemical dissimilatory biodeterioration (corrosion), occurs when the microbial metabolites damage the material¹².

In the case of masonry, the chemical assimilatory corrosion is of little importance due to the minimal amount of nutrients in the facility. It is limited only to those walls in which wooden elements were used in the structure or wood was used as a material for roofing elements, communication, e.g., bridges and viewpoints on the crown of the walls.

The phenomenon of dissimilatory biological corrosion is of great importance. The fouling of the surface of materials by living organisms, known in the literature as "biofouling" can cause a number of adverse changes inside and on the wall surface, corrosion, pigmentation, secretion of toxic metabolites to the material, and damage to the masonry structure due to root system growth¹³.

The development of biological corrosion and vegetation causes a number of adverse changes in the ruin. These changes can be divided into: technical, aesthetic, and hygienic-sanitary. Technical effects mainly consist in lowering the strength of elements and structures, which leads to their slow degradation. The biological corrosion also has aesthetic significance, it results in lowering the aesthetic values of the elements infected. The hygienic-sanitary effects, leading to deterioration of the health safety of objects for people and animals, in the case of walls in ruin are not significant¹⁴.

From the conservation point of view, the technical effects caused by biological corrosion and vegetation development are by far the most important for the ruins. Therefore, due to the technical nature of the study, in the next part, the greatest emphasis will be placed on the impact of biological corrosion on the degradation processes of ruins, and on the principles of handling the removal of organisms that cause biological corrosion and undesirable vegetation.

The mechanism of biodegradation of objects protected in the form of ruins is complex and depends on many factors. The most important are: the material from which it was erected, the construction height and thickness of the walls, a moisture status of the walls, the place where it was erected, the type and size of trees in the immediate vicinity, types of organisms inhabiting the walls, quality of care by the manager, etc. All these factors have a smaller or greater impact on the technical condition of the walls associated with the adverse effects of organisms that cause biological corrosion and the presence of undesirable vegetation.

Due to the large variety of damage caused by living organisms, their division into three groups has been proposed. The division takes into account the depth of damage and assigns them groups of organisms responsible for the destruction.

- Group I - surface damage/algae, bryophytes, molds, and lichens/
- Group II - damage to the deep strata and crowns/low vegetation - grass, perennials, and succulents/
- Group III - damage to the structure/high vegetation - trees and shrubs/

Group I - surface damage

The first group includes damage caused by the development of organisms devoid of root systems or those in which they have a residual form. This group includes algae, lichens, bryophytes, and molds. These organisms usually only cover the surface of the material. Due to different environmental requirements (humidity, pH of the substrate, sun exposure) they can develop in various

12 Strzelczyk A. B., Czynniki niszczące kamienie. Czynniki biologiczne, [w:] Zabytki kamienne i metalowe ich niszczenie i konserwacja profilaktyczna, red. Wiesław Domasłowski. Wydawnictwo Naukowe UMK, Toruń 2011, s.135-157

13 Jasięko J., Mierzejewska O., Hamrol K., Misztal W., Utrwalanie koron murów obiektów historycznych przez-naczonych do ekspozycji w formie trwałej ruiny, „Wiadomości konserwatorskie” nr 30, 2011, s. 117-132

14 Sieniawska-Kuras A, Potocki P., Przyczyny zniszczeń obiektów budowlanych i elementów architektonicznych. Procesy biologiczne. [w:] Renowacja elementów architektury. Wydawnictwo i handel książkami „KaBe”, Krosno 2012, s. 53-55

places and on most materials found in objects.

Algae, bryophytes, and molds have quite high requirements for the moisture of the ground, which is why they grow over the basement strip of the walls and in shady places. The largest concentrations of these organisms are observed on the walls facing north. Their habitat is usually natural stones and brick, but they also occur on joints and plasters. Initially slow expansion becomes more and more intense. It is caused by the ability to retain moisture by algae and bryophytes, which leads to even greater moisture content in the substrate. As a consequence, further organisms develop on moist surfaces. Their development usually ceases when the humidity conditions change.

Lichens have much lower requirements for the substrate moisture. They are quite resistant to low and high temperatures. Thanks to the possibility of absorbing moisture from the air, they are independent of the ground conditions. They grow on stones, bricks, joints, and plasters. Their colors vary widely from bright ones to black. Due to the color of the fruiting bodies, they are often treated as a dirt.

The surface damage made by some species of lichens is caused by the secretion of acids and the growth of cells in the pores of the stone. Algae and fungi also secrete organic acids, especially the oxalic acid. Additionally, due to the growth of the fungal hyphae into the pores of materials, their cohesion may be loosened, thus the surface layer is destroyed. In turn, the sulfur bacteria in the metabolic process cause the formation of sulfuric acid and initiate a series of chemical reactions resulting in cracking and crumbling of materials. The nitrifying bacteria oxidize the ammonia (contained in rainwater, dust, and soot) to nitric acid, which, e.g., dissolves surface layers of stones creating characteristic stains and craters or the so-called snow blooms¹⁵.



Photo 23. *Algae colonies on a moist ceramic brick wall.*



Photo 24. *The development of algae and lichen in the corner of the wall directly under the ivy, which grows on the wall and the crown.*

¹⁵ Ferraby S., The ecology of ruin sites [w:] Conservation of Ruins, ed. John Ashurst, Elsevier Science & Technology, 2006, s. 209 - 210



Photo 25. A fragment of a plastered ceiling overgrown with lichens.

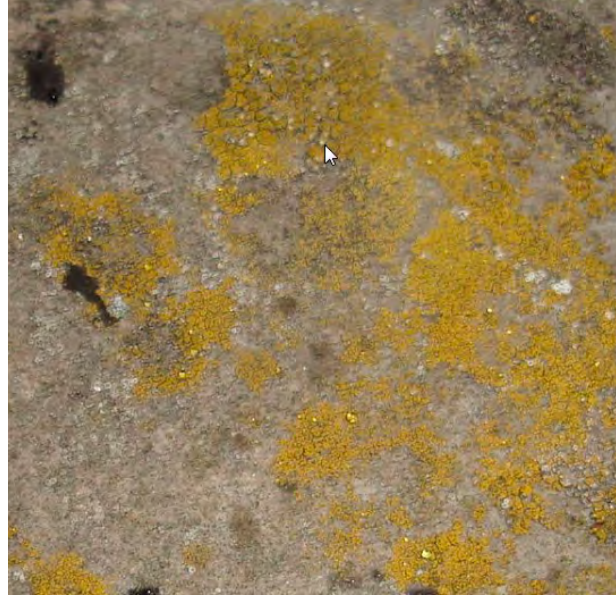

Photo 26. Colonies of lichens on historical plaster of the external wall of an object.



Photo 27. Mosses growing on the low crown of the north wall of the ruin.



Photo 28. Moss and algae, which overgrow the crown and the face of the wall.

Group II - damage to the depths and crowns

The second group includes deep damage to the surface layers of the wall /face and crown/. Destruction is caused by small plants developing a root system, and consequently requiring a suitable substrate or a place where they can grow. This group includes all species of low vegetation in buildings in ruins: grass, perennials, ivy, and succulents.

The development of green plants begins with the appearance of a minimum amount of humus in the crevices and on the crown of the wall. Initially, mainly small annual plants and grass dominate. Over time, perennial plants appear along with the growth of the humus layer (plant decomposition, wind blowing). Their growth is particularly intense in places where elevated humidity persists, however, many species are able to settle on dry and sunlit fragments.

The growth and decay of vegetation causes the appearance of the humic acids in the wall and an increase in the amount of nitrates. Acids cause dissolution of binders in the joints, weakening them and, consequently, some damage to the face of the wall. The increase in nitrate concentration is responsible for further damage to the surface layers. Crystallizing salts increase their volume and break the pores of welds and masonry materials. The crystallization pressure is so high that damage occurs even in the case of rocks with high hardness.

Another consequence of the development of low vegetation is damage at the interface between the weld and masonry related to the development of the root system. The expanding roots cause damage to weak /mostly made of lime or clay/ joints, which can lead to further damage to the face layers /individual detachments of small stones or entire fragments.

Chemical substances released by vegetation and derived from their decomposition also result in the discoloration of the face surface causing negative aesthetic effects.



Photo 29. Photograph of a heavily sunlit southern façade. The development of vegetation in the wall crevices.



Photo 30. Damage to the face of the wall associated with the growth of the root system of low vegetation.



Photo 31. The crown and the face of a curtain wall overgrown with annual and perennial vegetation.



Photo 32. The expansion of low plants and mosses on the crown of a ceramic brick wall. In the foreground young shrubs are visible.



Photo 33. *The low crown of the wall completely overgrown with greenery. The tight layer of humus and greenery prevents evaporation of the moisture retained in the wall.*



Photo 34. *A wall relic covered with vegetation. A large amount of greenery causes the illegibility of the ruin.*

Group III - damage to the structure

The third group includes the large-area damage to the face and wall construction itself. It is caused by perennial plants, whose the root system is very extensive and surpasses the walls or vaults of the object. The third group type of damage is caused by trees and shrubs.

The impact of high vegetation on the walls is much greater than in the other groups of organisms described in the previous subsections. The roots secrete large amounts of organic acids that cause the decomposition of calcium carbonate in the joints of the masonry walls. This leads to weakening of the joint-masonry bonds inside the wall. Together with water, these compounds move to the surface, and then after evaporation of water, they crystallize. The crystallization causes sealing of near-surface layers and appearance of carbonate stains.

Falling leaves are found in the crevices and hollows of the wall, and after decomposition they form the basis for the development of low vegetation and bryophytes. In addition, along with water, large amounts of nitrates from the decomposition of leaves enter the wall.

Trees and shrubs also affect the ruin mechanically. The growing roots fill the walls' gaps and cause the emergence of new cracks and surface spalling of stone and brick. Large root systems overwhelming the walls over time can lead to large surface loosening and significant damage to the construction of the entire wall.

The presence of tall trees overgrowing walls or located in their immediate surroundings can also be very dangerous during intense storms or strong winds. An uprooted or broken tree can cause to significant damage to the ruins or pose a threat to the people staying in the facility.

Constant shading of the wall by high vegetation hinders its drying out, which can lead to intensive development of low vegetation, algae, and bryophytes.



Photo 35. A fragment of the vault intensely overgrown with shrubs.



Photo 36. A stone wall with young birches growing on the crown.



Photo 37. The rowan rooted in the gap between the wall of the crown and the lintel.



Photo 38. A shrub with a root system growing into a ceramic brick wall

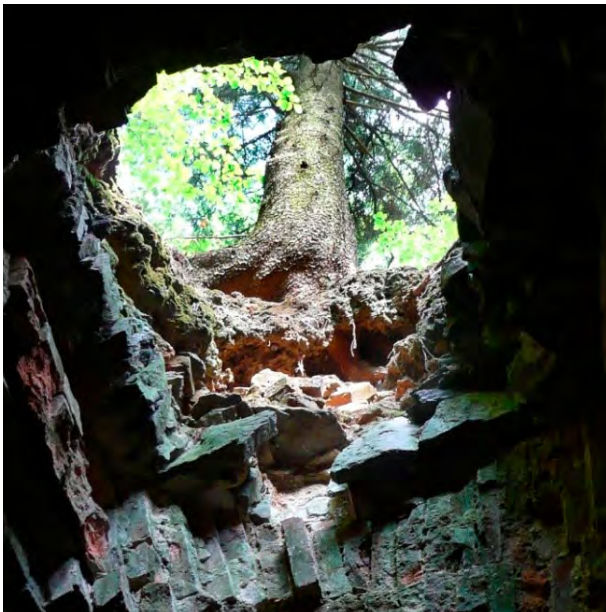

Photo 39. A vault made of ceramic brick damaged by roots.



Photo 40. A huge tree and its root system, which has overgrown a stone vault.

Problems concerning the impact of vegetation on objects in permanent ruin is an open issue, which is dealt with by architects, conservators, and engineers. In a large number of scientific and popular science publications, a separate group consists of guides for managers and guardians of objects ¹⁶. Guidelines indicate the need to consult specialists before starting any activities related to the treatment of vegetation growing on objects in the state of permanent ruin.

The removal of organisms responsible for the development of biological corrosion is associated with the need to conduct activities that directly or indirectly can affect the behavior of the ruin itself. Due to the possibility of adverse changes during this work: structural damage, surface damage to the face, damage to the details, change of color, etc., removal of organisms responsible for corrosion should be subject to specific rules. Due to the differences related to the structure of organisms (lack or existence of root systems), the place of occurrence and the type of damage caused by the action of organisms, the rules of conduct were collected in two groups.

Rules for the removal of algae, lichen, mosses, and mold fungi

- Determination whether the existing organisms must be removed or whether their impact on the material is negligible and they can remain.
- Determination the degree of damage and its type.
- Adoption of the method of removing the organisms. The method must take into account the surface, the availability, the texture of the material, the strength of the subsurface layers, and the degree of damage.
- For mechanical removal, it is necessary to carry out tests of cleaning efficiency and the impact of the method used on the substrate.
- The use of chemical preparations that combat organisms requires determining the effect of the substance on the treated surfaces. The compounds contained in the substances used must not cause changes in the structure, reduce the strength or cause changes in the color scheme of the material.
- After cleaning works, the wall surface should be disinfected.
- Determination of the time after which the treatments need to be repeated.

Rules for handling unwanted vegetation

- Before starting the work, review the condition of the walls and determine the places where the work will be carried out should be performed.
- Determination which plant groups are to be removed. In certain cases a decision may be made to leave some plants or their parts (ivy, grass growing on protected wall crowns).
- If there is a need for work at high altitudes, especially when cutting out trees, works should be outsourced to specialists.
- Annual and perennial plants (grasses, perennials, and weeds) should be removed as much as possible with the whole root system.
- After removing the plants from gaps and depressions, the layers of soil that are located there should be also removed, if possible. This treatment will delay the growth of other organisms in the future.
- Before using chemical preparations, each time it is necessary to determine their impact on the material of the ruin.
- The chemicals used within the ruins must not adversely affect the planned vegetation.
- Removal of tall trees both near the walls as well as those with a root system overgrowing the structure must be supported by the analysis of the impact of the cut on the behavior of the walls.

¹⁶ Donnelly J., Ruins: the Conservation and Repair of Masonry Ruins, Government Publications Sales Office, Dublin, 2010, Eklund J. A., Young M. E., Biological Growth on Masonry: Identification & Understanding. Inform. Information of historic building owners. Published by Historic Scotland, January 2013, Fawcett R., Treatment of vegetation at monuments [w:]The Conservation of Architectural Ancient Monuments in Scotland. Guidance on Principles. Published by Historic Scotland. Longmore House. Salisbury Place. Edinburgh 2001, s. 44-47, Kozarski P., Molski P., Zagospodarowanie i konserwacja zabytkowych budowli. Towarzystwo Przyjaciół Fortyfikacji, Fortyfikacje tom XIV, Warszawa 2001

- It is not recommended to remove trunks and roots after tree felling, if they affect the stability of slopes near the walls and the stability of the walls themselves.
- In the case of removal of trees and shrubs, it is necessary to take into account breeding and nesting periods of birds.
- After clearing the ruin of undesirable greenery, it is recommended to periodically monitor the walls and carry out works preventing fouling.

The development of organisms on the walls of objects protected in the form of the permanent ruin is an unavoidable process. The specificity of these buildings (objects which are unroofed, unheated, and often unused and unprotected) means that under favorable conditions that prevail there, organisms will develop all the time. It is important that this development is not left uncontrolled. Depriving the walls of care for only a few years can lead to a series of destructions, often of an irreversible nature.

Therefore, it is crucial that such objects should be subject to periodic inspections, allowing to carry out cleaning works at the moment when corrosion or vegetation growth occurs. Properly conducted inspection allows to decide which species and specimens should be immediately removed, and which left and treated as an element of the arrangement. Cyclical activities will not allow excessive growth of vegetation and will reduce the costs of activities related to the removal of vegetation.

4. Laboratory tests of materials and structural elements

4.1. Compressive strength test

During the analysis of the structure, the most important parameter is the compressive strength of its components and the structure itself. The necessity to carry out strength calculations may be caused, among other things, by the need to load the structure, change the static scheme, adapt it, add superstructure, extend, reconstruct, etc. Currently, several non-destructive or medium destructive methods (described in the first part) are used to determine this parameter. On the basis of numerous studies, the error of the strength estimation by means of indirect methods at the level of 20% was found. In order to obtain a very accurate result, a destructive laboratory test should be performed.

The purpose of the test

The purpose of the test is to determine the compressive strength of the masonry. In addition, it is also possible to determine the splitting tensile strength, Young's modulus, and Poisson's modulus on samples are taken. The result of the test is the actual strength of the wall fragment, which is expressed in pressure units.

Research methodology

At present, there are no standards that explicitly regulate the conduct of research for the historic ruin objects. Records regarding similar research on contemporary objects can be found in national standards and instructions issued by research institutes [sources].

In order to determine the strength parameters using the laboratory method, a sample of the construction element tested should be taken, then it should be properly prepared and compressed to be destroyed in a hydraulic press.

Conducting the study

Before proceeding with the test, samples should be taken from the element. The method of taking samples and their preparation is important for the final result of the test, therefore in the case of comparative testing, identical methods are recommended.

According to the sets of standards and regulations, a minimum of 3 samples should be taken. However, due to the large diversity and difficulties associated with taking samples in historic buildings, it is recommended to take a minimum of 6 samples.

Sampling from the wall is carried out using a driller with a hole saw drill bit. The hole saw bit may be liquid-cooled during sampling and the moisture of the material will affect the strength result. It is recommended to perform tests after the wall is completely dry.

The diameter of the sample will depend on the structure of the element and the assumed precision of the test (best results are obtained for 150 mm cores). The diameter should be chosen so as to render a representative part of the wall and cause the smallest damage to the structure of the element tested.

The depth of the borehole will depend on the thickness of the wall and the lace. If the walls are not too thick, taking samples from the entire thickness of the masonry and testing the central part is recommended. In the case of walls of considerable thickness, it is recommended to take samples 5 cm larger than the inner diameter of the hole saw drill bit (e.g., for the Ø150 mm hole

saw bit, the sample length should be 200 mm). A few additional centimeters of the sample height are necessary due to frequent surface damage to the face layer and uneven fracture during its collection. The lateral surfaces of the sample should then be ground so that they are perpendicular to the cylindrical surfaces and parallel to each other.

Samples prepared for testing should be in the 1:1 proportion (diameter:height). In the case of testing the strength of the entire wall and not its elements, the sample should be collected in such a way as to render the composite as accurately as possible (it should contain a mortar and the masonry material). The more symmetrical the side surface view is, the more reliable test results will be. Depending on the size of the wall elements, the joint should be as close as possible to the center and the central axes should form the symmetry axes of the sample.

Properly prepared samples can be pressed parallel or perpendicular to the load direction in the wall. The composite is anisotropic and will exhibit different material parameters depending on the direction of the test. It is recommended to compress the element in the direction in which the element is compressed in the wall. The sample scheme together with the test diagram is shown below.



Figure 10. Diagram of the test of the wall core¹⁷



Photo 41. A core through the thickness of the wall.¹⁸



Photo 42. Samples prepared for testing.¹⁹

¹⁷ UIC - International Union of Railways: UIC code 778-3R - final draft 2008, Recommendations for the inspection, assessment and maintenance of masonry arch bridges.

¹⁸ Gruszczyński M., Matysek P., Estimation of masonry walls strength based on drilled cores tests, REW-INŻ'2011 (9; 2011; Kraków, Polska.

¹⁹ Gruszczyński M., Matysek P., Estimation of masonry walls strength based on drilled cores tests, REW-INŻ'2011 (9; 2011; Kraków, Polska

Properly prepared samples are placed in a hydraulic press and then they are subjected to compression with a corresponding increase in force (N/s). The force increase should be set individually in each test depending on the structure of the element being tested.



Photo 43. Test station - the Controls Advantest 9 hydraulic press

Interpretation and presentation of the results

The compressive strength f , which is expressed in MPa is calculated using the formula:

$$f = n \times \frac{F}{\varphi \times l}$$

where:

- f - destructive force
- φ - diameter of the sample
- l - length of the sample
- n - correlation coefficient

Accuracy of calculation up to 0.1 MPa.

The correlation coefficient based on the tests²⁰ is recommended to be between 1.8 and 2.2. It depends on: the proportion of the sample, its diameter, and the slenderness of the element tested. It should be adopted individually based on the experience of a laboratory technician or expert.

When analyzing the results, it is also important to determine their standard deviation. It will prove the homogeneity of the element tested or the accuracy of the research conducted.

Test report

The test report should contain the following information:

- date and place of sampling,
- type and origin of the element,
- number of samples taken,
- date of receipt of samples by the research laboratory,
- sketch of the sample, if necessary, showing the area of the surface to be loaded, the size and direction of the load,
- the method used to prepare the surface,
- humidity during the test (measured by gravimetric method on samples after destruction),
- destructive load in N and dimensions of each sample in mm,

²⁰ Brencich A., Sterpi E., Compressive strength of solid clay brick masonry: calibration of experimental tests and theoretical issues, Structural Analysis of Historical Constructions, New Delhi 2006

- strength of samples in MPa with an accuracy of 0.1 MPa,
- description of the type of destruction for each sample,
- photographic documentation from the study,
- conclusions if there are any.

4.2. Tests of physical properties of materials

4.2.1. Compressive strength and bending strength test

Compressive strength test

Strength tests are carried out in order to check what amount of force acting on the element will cause its destruction. The type of strength test is selected depending on the subsequent use and nature of the element's performance. For elements with a shape similar to a cube (masonry elements, pavement), the compressive strength is primarily determined. For elongated elements (window sills, window bands, lintels, curbs), the bending strength is checked. In the case of cladding elements (façade panels), mounted on anchors, the force is determined as applied to the connecting elements (anchors), at which the connector will be torn together with the piece of a plate.

In buildings in ruins, these tests are carried out both in the case of historical material and materials introduced during conservation and renovation works.

The tests are carried out on six samples with a shape similar to a cube and an edge length of approximately 70 mm. The face surfaces to be loaded should be prepared in such a way that they are flat with a tolerance of 0.1 mm. The dimensions of the cross-section for testing are measured to an accuracy of 0.1 mm, and represent the average of two measurements taken at right angles to each other, in the upper and lower parts of the height of the sample. The average lateral dimension is used to calculate the area of the cross-section. The height of the sample is determined with an accuracy of 1 mm. Samples before compression are dried to a constant mass at a temperature of about 70 °C. Then after cooling in the desiccator, they are tested in a strength test machine. The exceptions are stone tests for hydrotechnical works (canals, gutters, etc.) - the stones are soaked with water to simulate the conditions in which destructive forces actually act on the element.

The pressure surfaces of the testing machine must be cleaned. The sample is placed exactly in the middle of the bottom plate of the device. The machine load should increase continuously with a constant velocity of compressive stresses (1 ± 0.5) MPa/s. The maximum sample load is quoted to the nearest 1 kN.

As a result of testing the compressive strength of samples, the quotient of the force at which the sample has been destroyed to the surface area of its cross-section is taken. This dependence is described by the following equation.

$$R = \frac{F}{A}$$

where:

R - compressive strength [MPa]

F - destructive force [kN]

A - cross-section area [mm²]

The test description in accordance with the PN-EN 1926:2007 standard: Natural stone testing methods - Determination of compressive strength

Tests of mortars (depending on the purpose of the materials tested) should be carried out in accordance with the PN-B-04500: 1985 standard: Building mortars - Physical and strength tests or PN-EN 13892-2:2004 Methods for testing materials for floor underlays - Part 2: Determination of bending and compressive strength. The test is performed on the halves of the 160*40*40 mm samples, after the bending strength test.

Research for bricks should be carried out in accordance with the following standard: PN-EN 772-1+A1: 2015-10 Test methods for masonry components - Part 1: Determination of compressive strength. The tests are carried out on masonry elements with leveling mortar or on cut and polished samples without leveling mortar. The test is made on 6 samples.

Tab. 6th List of measurement results of samples for the compressive strength test

Sample No.	Mass of samples before drying m1 [g]	Mass of samples dried to a constant weight m2 [g]	Side dimension a [mm]	Side dimension b [mm]	Height h ₁ [mm]	Height h ₂ [mm]	Average height h _{sr} [mm]	Cross-section area A [mm ²]
1
2

Tab. 7th Comparison of the obtained compressive strength test results

Compression			Compressive strength calculated for individual samples R [MPa]	Average compressive strength [Mpa]
Load F [kN]	Stresses [MPa]	Time t [s]		
1			...	
2			...	



Photo 44. Sandstone samples prepared for compressive strength testing.



Photo 45. A strength testing machine with an extension for examination.

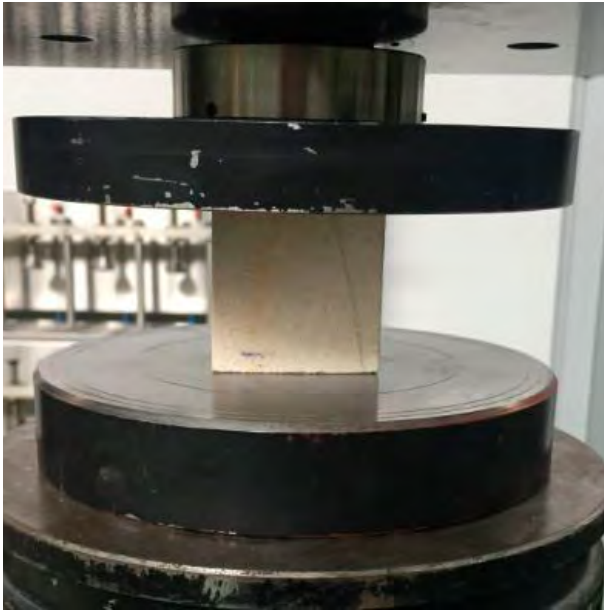

Photo 46. The process of sandstone sample compression.



Photo 47. A view of the destroyed sample after the test.

Description of the bending strength test for mortars

The tests are conducted based on the PN-EN 1015-11 standard and the guidelines contained therein. Three cuboidal samples, which have reached a standard strength, i.e., samples maturing for 28 days from the date of their formation, are used for the determination. The dimensions of the samples should be equal to 40x40x160 mm. Each sample should be appropriately and legibly marked. Determination of the bending strength of the samples is done by loading them at 3 points, until they are broken. Before placing samples in the machine intended for the test, their surface should be cleaned from impurities in the form of free grains and dust.

The samples are then placed in a testing machine on special roller supports, next a bending load is applied. This load should be increased uniformly from 10 to 50 N/s. The test is completed at the time the bar is destroyed, i.e., when it is broken. The maximum applied load is treated as a breaking load. The halves of the samples remaining after the test are put away for further use in the compressive strength tests. The flexural strength of a single rectangular sample is determined by the following formula:

$$f = 1,5 \frac{F \cdot l}{b \times d^2}$$

where:

b, d, l - internal dimensions of the mold in which the samples were made

F - maximum force causing destruction of the sample

The results obtained should be given with the accuracy of 0.05 N/mm². The average value of bending strength should also be calculated.

Test description in accordance with the PN-EN 1015-11 standard: Mortar testing methods for masonry. Determination of bending and compressive strength of the hardened mortar.

In the case of testing mortars used as flooring in buildings, the following standard should be used: PN-EN 13892-2:2004 Methods for testing materials for floor underlays - Part 2: Determination of bending and compressive strength.

Tab. 8th The results of the mortar tensile strength test.

Sample No.	The individual dimensions of the samples sides			Bending			Bending strength calculated for individual samples R [MPa]	Average bending strength [MPa]
	Side dimension a [mm]	Side dimension b [mm]	Length l [mm]	Load F [N]	Stresses [MPa]	Time t [s]		
1
2	



Photo 48. Mortar samples molding



Photo 49. The process of testing a sample of conservation mortar in a strength testing machine.



Photo 50. View of the sample after bending strength test.

4.2.2. Abrasion test

Abrasion of materials occurs primarily on horizontal surfaces on which pedestrian traffic or vehicle movement take place. The tests are aimed at determining the susceptibility of a material to abrasion during its use. In buildings in ruin, it is the test performed in the selection of materials for making floors inside objects and communication routes. This test is carried out on various types of

disks and on samples of various shapes. The Boehme's disk is most commonly used.

The test is conducted based on PN-EN 14157:2017-11. The test is carried out on 3 cubic samples with an edge of approximately 70 mm. The wearing surface is approximately 50 cm². The samples to be tested are dried to a constant mass at a temperature of about 70 °C. The heights of the samples are measured along straight lines perpendicular to the base, taken from the center of each of its four edges. The abraded surface must be flat sanded.

The test is performed on the Boehme's disk. The sample, after being placed in the holder, is pressed to the disk with a concentrated force of 30 kg (294N). The surface of the disk over the entire length of the abrasion belt is sprinkled with twenty grams of an electro-corundum abrasive powder. After the powder has been poured, the disc is rotated and the abrasive powder is scraped onto the abrasive belt. 16 cycles with 22 turns are performed. After every 22 turns, the material and powder should be removed from the disc, then the abrasion belt should be sprinkled with a new portion of 20 g of the abrasive powder. The disk is restarted after the sample has been rotated by 90 degrees.

After 352 turns, the test is completed. The sample is removed from the holder and its height is measured by a caliper with an accuracy of 0.01 cm. The height change is calculated as the difference before the test and after the examination of the average height of the sample, obtained from the arithmetic mean of heights measured along the perpendicular straights to the base, and derived from the center of each of its four edges.

The measure of abrasiveness is the loss of the sample volume calculated as the product of the surface area and the change in the height of the sample.

Tab. 9th Results of the test of abrasiveness of natural stone - height loss

Sample No	The height of the sample before abrasion test				The height of the sample after abrasion test				The average height of the sample before the test ΔH_1 [cm]	The average height of the sample after the test ΔH_2 [cm]	The results of the test in [cm]
	h_1 [cm]	h_2 [cm]	h_3 [cm]	h_4 [cm]	$h_{1'}$ [cm]	$h_{2'}$ [cm]	$h_{3'}$ [cm]	$h_{4'}$ [cm]			
1											
2											



Photo 51. Abrasion testing device - the Boehme's disk.



Photo 52. A stone sample mounted in the device holder.



Photo 53. A sample during the abrasion process.



Photo 54. A limestone sample after completion of the test.

4.2.3. Water absorption of materials

Water absorption of a material is the ability to completely absorb water through pores and capillaries. It is defined as the percentage of water content in relation to the mass of material or its volume. In practice, it is the maximum moisture of the material.

Materials with closed pores or their prevalence and materials with low porosity show very low absorbability. Under natural conditions, water displaces only a part of the air from the pores of the material. In very small pores it replaces about 30% of the air volume, in large ones up to 70%. The absorbability of building materials varies from 0% by weight (glass, metals) to above 200% by weight (wood or some very porous materials).

The purpose of the test is to determine the maximum absorbability of a masonry material or mortar. Studies are carried out both in the case of historical material and new materials introduced during the conservation works. Information obtained during research can be useful for the selection of materials for repairs and additions, when it is important that the materials introduced have properties as similar as possible to the historical materials. The tests of absorbability of materials are also performed in the case of works related to the impregnation of masonry materials. Determination of the water absorption is one of the basic tests to check the effectiveness of hydrophobic preparations. The high absorbability tested should also be a recommendation for other tests, e.g., frost resistance or abrasion resistance.

The n_m [%] mass water absorption means the ratio of the mass of water absorbed by the sample to the mass of the sample in the dry state.

$$n_m = \frac{m_n - m_s}{m_s} 100\% = \frac{m_{water}}{m_s} 100\%$$

Where:

n_m - mass water absorption [%],

m_n - mass of the sample in the state of water saturation [kg, g],

m_s - mass of the dry sample [kg, g],

m_{water} - mass of water in the sample [kg, g].

The n_o [%] volumetric water absorption means the ratio of the volume of water absorbed by the

sample to the volume of the sample in the dry state.

$$n_o = \frac{m_n - m_s}{V} 100\%$$

Where:

n_o - volumetric water absorption [%],

m_n - mass of the sample in the state of water saturation [kg, g],

m_s - mass of the dry sample [kg, g],

V - sample volume in the dry state [m³, cm³].

4.2.4. Testing the water absorption of natural stone at atmospheric pressure

The test is carried out on six samples with a shape similar to a cube with an edge of approx. 70 mm. The samples for testing should be dried to a constant mass at a temperature of approximately 70 °C. After drying, the test specimens should be weighed with an accuracy of 0.01 g. They are then stored in a desiccator until the temperature reaches approximately 20 °C.

The next step is to place the material in the container on the washers. Each sample should be placed at least 15 mm away from adjacent samples. Then tap water is added at a temperature of about 20 °C up to half the height of the samples.

After the time t_o equal approximately 60 min, the water level is adjusted to 3/4 of the height of the test samples.

After the time t_o of about 120 minutes, water is added up to the total immersion of the samples under water to a depth of about 25 mm.

After the time t_o of about 48 hours, the sample is removed from the water, wiped rapidly with a damp cloth and then weighed to the nearest 0.01 g. Then the samples are again immersed in water and the test is continued.

After every 24 hours, the samples are removed from the water, then wiped with a damp cloth and weighed within 1 minute with an accuracy of 0.01 g. The weighing should be terminated after reaching a constant mass of the samples.

The A_b water absorption at atmospheric pressure is calculated from the equation

$$A_b = \frac{m_s - m_d}{m_s} \cdot 100$$

Where:

m_s - mass of the water-saturated sample [g],

m_d - dry sample mass [g],

A_b - water absorption at atmospheric pressure [%].

The result is given as percentage with rounding to 0.1%.

Description of the test in accordance with the standard: PN-EN 13755 Methods for testing natural stone. Determination of the water absorption at atmospheric pressure.

Mortars testing should be carried out in accordance with the PN-B-04500: 1985 standard: Building mortars - Physical and strength tests. Dimension of samples for testing equal 160x40x40 mm, a minimum number of samples equal to 3. According to the description, three different methods can be used for soaking samples: soaking method, cooking method, cooking and soaking method.

Studies for bricks should be carried out in accordance with the following standard: PN-B-12016: 1970 Construction ceramics products - Technical studies. The tests are carried out on masonry elements and the designation is carried out on 6 samples.

Tab. 10th Calculation of water absorption at atmospheric pressure of natural stone samples

Sample No.	Mass of samples dried to the constant mass m_d [g]	The mass of the samples after 48 hours of testing m_{s1} [g]	Mass of samples completely soaked in water m_s [g]	Calculated absorptivity of the samples with water A_b [%]
1
2



Photo 55. Investigation of water absorption of sandstone at atmospheric pressure. Drying of samples.

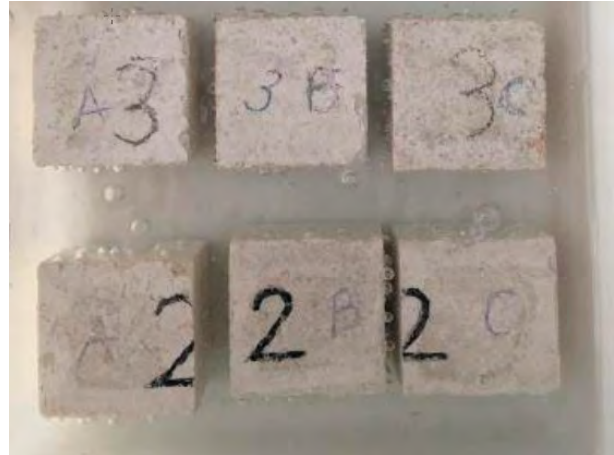

Photo 56. Investigation of the water absorption of sandstone at atmospheric pressure. Soaking of samples.

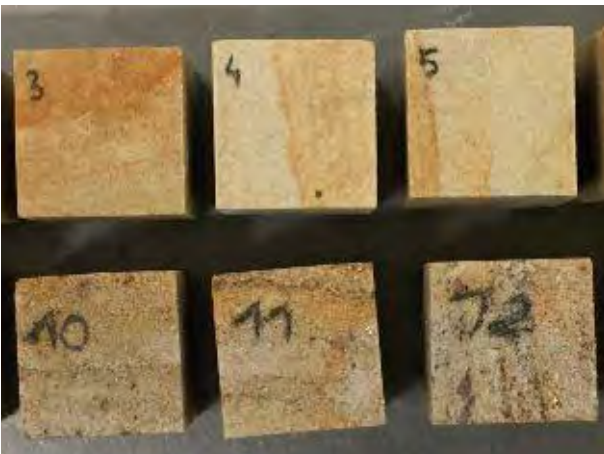

Photo 57. Investigation of the water absorption of sandstone at atmospheric pressure. A view of samples after testing.



Photo 58. Investigation of water absorption of lime mortar at atmospheric. Soaking of samples.

4.2.5. Capillarity of materials

Most building materials, including natural stones, mortars, and ceramics are porous materials that have the ability to pull up water. The process of pulling up water is referred to as the capillarity. Capillaries in some materials cause the water to be pulled up into the internal structure of these materials when they come into contact with a moist substrate. The amount of capillary rise is dependent on the contact angle (liquid type) and the capillary diameter (pore size). The smaller the pore diameter, the greater the capillary rise. Capillary rise is one of the main sources of dampness in historical ruins.

The aim of the study is to determine the susceptibility of the materials (masonry or mortar) tested to the capillary motion in their structure. Research is carried out both in the case of histori-

cal material taken from the facility and new materials that are to be introduced into the historical matter. It is important that the materials introduced (bricklaying, supplements) have similar capillary properties as the historical material. This is particularly important in the case of work carried out on face layers. In the case of large differences in capillarity, a situation may arise in which the newly introduced material will clearly raise water from the ground or be subjected to a high moisture from atmospheric precipitation. As a consequence, it will lead to a faster degradation of the face layers of restorations, occurrence of moisture stains, faster growth of algae and other organisms causing biological corrosion. In a relatively short time, the aesthetics of the repaired fragments will also deteriorate.

Determination of the capillary absorption coefficient of natural stone

The test specimens should have a rough cutting surface or they may have one or two polished or split surfaces. These surfaces should be placed vertically (the work surface must never be submerged).

The test pieces shall have the shape of cubes with sides of (70 ± 5) mm or (50 ± 5) mm, or cylinders whose diameter and height shall be equal to (70 ± 5) mm or (50 ± 5) mm.

The test samples shall be dried to a constant mass in a ventilated oven at a temperature of (70 ± 5) °C. The constant mass is achieved when the difference between two consecutive weighings in time (24 ± 2) h is not greater than 0.1% of the sample mass. Samples should be stored in a desiccator at room temperature (20 ± 5) °C.

After drying, the samples should be weighed (m_d) to the nearest 0.01 g, the surface of the immersed base should be determined by measuring two of its mediansto the nearest 0,1 mm. The surface should be expressed in square meters. The samples should be placed in the cuvette, with the planes of anisotropy in the direction of rising water. The sample base should be immersed in water to a depth of (3 ± 1) mm. The stopwatch must be started. A constant water level throughout the test must be maintained, adding it if necessary. The cuvette should be covered to avoid evaporation of moisture from the samples. Initially, after a very short immersion time, then longer immersion time, the samples are removed one after the other, the wet part of each sample is gently wiped until the droplets of water are removed. Next, the samples are weighed immediately to the nearest 0.01 g, then put back into the cuvette. The time elapsed since the beginning of the test until each weighing is recorded.

For a very absorbent stone, the right time intervals f are: 1, 3, 5, 10, 15, 30, 60, 480, and 1440 min. These times should be measured to an accuracy of 5%. A minimum of 7 measurements is required. The test is considered as complete when the difference between two consecutive weighings is no more than 1% of the water absorbed by the sample.

If the correlation coefficient between the measured points in the first part of the graph and the regression line of this first part is respectively greater than 0.90 (when at least five measurements have been taken to obtain the first part of the graph) or greater than 0.95 (when only four samples have been taken), the C_1 or C_2 capillary absorption coefficient (in grams per square meter and per square root of time in seconds) is expressed as the C_1 slope to the C_2 regression line. It can be calculated as the ratio between the ordinate and the abscissa at each point of the line, according to the following formula:

$$C_1 \text{ lub } C_2 = \frac{m_i - m_d}{A * \sqrt{t_i}}$$

Where:

m_d - mass of the dry test sample, in grams.

m_i - consecutive sample weights in the course of the test, in grams;

A - surface immersed in water, in square meters;

t - time elapsed from the beginning of the test to the point at which the next sample mass was measured in seconds;

- C_1 - coefficient of the capillary water absorption. It is measured in the perpendicular direction to the plane of stone anisotropy, in grams per square meter and per square root of second
- C_2 - coefficient of the capillary water absorption. It is measured in the parallel direction to the plane of stone, in grams per square meter and per square root of second

Description of the test in accordance with the standard No. PN-EN 1925: 2001 Methods of testing natural stone - Determination of the capillary absorption coefficient.

Testing of mortars should be carried out in accordance with the following standard: PN-EN 1015-18:2003 Mortars testing methods for masonry - Part 18: Determination of the water absorption coefficient due to the capillary rise of hardened mortar. Dimension of samples for testing equal to 160*40*40 mm, minimum number of samples equal to 3.

Studies of bricks should be carried out in accordance with the standard: PN-EN 772-21: 2011 Test methods of masonry components - part 21: Determination of water absorption of ceramic and silicate wall elements by absorption of cold water, and PN-EN 772-7: 2000 Test methods of masonry components - Determination of water absorption of ceramic wall elements used in moisture-resistant layers by means of boiling in water. The tests are carried out on masonry elements and the designation is carried out on 6 samples.

Tab. 11th Calculations of the capillary absorption coefficient for a single sample of natural stone

m_d [g]	m_i [g]	$m_i - m_d$ [g]	A [m ²]	$\sqrt{t_i}$ [s]	C1		Y [g/m ²]	X \sqrt{t} [s]
...
...

m_d - the mass of the dry test sample [g], m_i - next mass of the sample tested [g], A - surface immersed in water [m²], t_i - time elapsed from the beginning of the test to the point at which the next sample mass was measured m_i [s], C_1 - the water capillary absorption coefficient, measured in the perpendicular direction to the plane of stone anisotropy [g/m²s^{0.5}], C_2 - the water capillary absorption coefficient, measured in the parallel direction to the plane of stone anisotropy [g/m²s^{0.5}], Y - water absorption in [g/m²], X - square root of time in [s^{0.5}].



Photo 59. Determination of the capillary absorption coefficient for limestone rock. The beginning of the study.



Photo 60. Determination of the capillary absorption coefficient for limestone rock. The end of the study.



Photo 61. Determination of the capillary absorption coefficient for lime mortars. The beginning of the study.



Photo 62. Determination of the capillary absorption coefficient for sandstone. The beginning of the study.

4.2.6. Resistance to salt crystallization

One of the most important processes responsible for the destruction of historic walls is the crystallization of building salts. With high moisture in the walls, building salts remain in the aqueous solution and do not cause any significant damage in this form. The problem is the process of crystallization in the moisture evaporation zone, i.e., at the limit of the maximum capillary rising and on the surface of the elements. In some places during crystallization, the salts increase their volume causing a number of significant damages to the masonry material, joints and finishing layers.

The purpose of the test is to determine the resistance to crystallizing salts in the surface layers and in the material cavities. These studies are conducted both in the case of historical materials and new materials introduced during conservation works. Newly introduced materials should have resistance similar to the resistance of historical materials.

Samples of 40 mm side length should be cut with a diamond saw and one of the surfaces should be ground, all loose material should be washed off the sample surface under running water. The samples for testing should be dried to a constant mass in an oven at 105 °C. The samples should be permanently marked and weighed to the nearest 0.01 g.

The test consists of 15 cycles, one cycle consists of 2 hours of soaking in a salt solution and at least 16 hours of drying in an oven at 105 °C.

- The dried samples should be placed in a container and covered with 14% saline solution to a depth of 10 mm above the surface of the sample. The minimum distance between samples should be 10 mm, and between the samples and the edges of the container - 20 mm. The samples should be soaked for 2 hours (20 °C) under cover to avoid evaporation.
- After soaking, the samples should be placed in an oven for at least 16 hours at 105 °C. In the initial stage of drying, in order to obtain a high relative humidity (before samples insertion), place the cuvette with water in the cold dryer and turn on the heating for 30 minutes.
- After each of the 15 cycles, the samples are stored in water at 23 °C for 24 hours, then they are dried to a constant mass and weighed²¹

The results should be presented using the formula:

²¹ PN-EN 12370 standard: Natural stone testing methods. Determination of resistance to salt crystallization

$$\Delta M = \frac{M_1 - M_{d1}}{M_d} \times 100$$

Where:

M_d - the mass of the dry test sample [g],

M_{d1} - the mass of the dried and labeled test sample before the first cycle [g],

M_1 - mass of the dried and labeled sample to be tested after 15 cycles [g],

ΔM - relative mass difference before and after the test (loss or weight gain) [%]

If the sample has been destroyed or broken during the test, the total number of cycles should be indicated.

Description of the test in accordance with the PN-EN 12370 standard: Natural stone testing methods. Determination of resistance to salt crystallization.

Mortar and brick tests are not covered by the standards.

Tab.12th List of results of the stone resistance test for salt crystallization

Sample No.	Mass of the dried sample M_{d1} [g]	Sample mass after 15 test cycles M_f [g]	Difference in weight [g]	Relative mass difference ΔM [%]	Average relative mass difference ΔM [%]	Visual assessment of damage on a scale from 1 to 5
1
2



Photo 63. Resistance test for salt crystallization. Limestone rock samples after 2 cycles.



Photo 64. Resistance test for salt crystallization. Limestone rock samples after 10 cycles.



Photo 65. Resistance test for salt crystallization. Samples of sandstone soaked in a saline solution.

Photo 66. Resistance test for salt crystallization. Sandstone samples after 10 cycles.

4.2.7. Determination of frost resistance

Significant damage to the walls of objects in ruins occurs as a result of cyclical freezing and thawing of water. The water in the pores and capillaries of the material, and in the cavities of the wall freezes and increases its volume, causing damage to both masonry and mortar. Degradation as a result of the so-called frost damage is particularly visible on the southern facades of facilities due to the multiple repetitions of freezing and thawing during one season.

The purpose of the test is to determine the frost resistance. These studies are conducted both in the case of historical material and new materials introduced during conservation works.

The frost resistance test is performed based on the guidelines contained in the PN-EN 12371: 2001 standard. In order to make the determination, 8 rectangular samples of size equal to 40x40x160 mm should be cut from the stone. For correct results, all samples are placed in an oven at 70 °C and dried to a constant weight before proceeding. The dried bars are placed vertically in the previously prepared container and set so that the distance between each of them is approximately 15 mm.

Clean tap water is poured into a container with vertically orientated samples, so that it reaches half of its height (80 mm). The whole set should be left for 60 minutes, after which the water level is increased to $\frac{3}{4}$ of the height of the cuboid samples. After 120 minutes, the water should be refilled, this time so that the bars are completely submerged to a depth of approximately 25 mm. Samples prepared in this way are left in a container for 48 hours.

After complete wetting of the samples with water, the frost resistance should be determined. For this purpose, they are placed in the chamber so that the distances between them are approximately 20 mm. The next step is to subject the samples to freezing and thawing cycles. Each cycle includes 6 hours of freezing the samples in the air, followed by another 6 hours of thawing them in water. The number of cycles depends on the strength of the samples - if they are destroyed before the maximum number of cycles (240), the test should be considered as completed.

After each series of 14 cycles, a visual assessment and measurement of their weight in air and water should be carried out.

In the visual assessment, the following scale is used:

- 0 - the sample for examination is not affected
- 1 - very small damage, sample is not disintegrated
- 2 - one or several small cracks, separation of small fragments $\leq 10\text{mm}^2$
- 3 - one or more cracks, separation of fragments $\geq 10\text{mm}^2$
- 4 - test sample broken into two parts or with significant cracks
- 5 - test sample in pieces

Achieving the third point of the scale causes the sample to be classified as damaged.

The following formula to measure the volume is used:

$$\Delta V_b = \frac{((M_{so} - M_{ho}) - (M_{sn} - M_{hn})) \times 100}{(M_{so} - M_{ho})}$$

Where:

M_{so} - mass of the sample to be tested in the air before freezing in [g]

M_{ho} - mass of the sample to be tested in water before freezing in [g]

M_{sn} - mass of the saturated sample after n cycles in [g]

M_{hn} - mass of the sample to be tested in water after n cycles in [g]

ΔV_b - change in sample volume after n cycles in [%]

The sample is classified as destroyed when the volume loss reaches 1%.

Test description in accordance with the PN-EN 12371 standard: Natural stone testing methods.

Determination of frost resistance.

Testing of mortars should be carried out in accordance with the following standard: PN-B-04500:1985 Building mortars - Physical and strength tests. Dimension of samples for testing equal to 160*40*40 mm. The number of samples should be 12 (6 in the frost resistance tester, 6 - witness samples).

Research on bricks should be carried out in accordance with the following standard: PN-B-12016:1970 Construction ceramics products - Technical tests. The tests are carried out on masonry elements and the designation is carried out on 6 samples.

Tab. 13th Frost resistance tests results for stone samples

Sample No.	M_{so} [g]	M_{ho} [g]	$V_{bo}=(M_{so}-M_{ho})$ [ml]	M_{sn} [g]	M_{hn} [g]	$V_{bn}=(M_{sn}-M_{hn})$ [ml]	ΔVb [%]	Visual evaluation of samples on a scale of 1 to 5
...
...



Photo 67. Frost resistance test. Soaking of sandstone samples.



Photo 68. Frost resistance test. Samples from limestone rock after 56 freezing cycles.



Photo 69. Frost resistance test. A sandstone sample after 30 freezing cycles. 4th degree damage



Photo 70. Frost resistance test. A sandstone sample after 30 freezing cycles. 3rd degree damage

4.3. Humidity testing by the gravimetric method

The basic sources of moisture supplying the walls are: water in the ground pulled up by capillary rise, water coming from atmospheric precipitation, water hygroscopically absorbed, and condensing inside the materials and on their surface. Other sources of moisture occurring in the construction industry that is, water technologically introduced into the facility, originating from installation failures, and generated by man are of little importance in the case of walls of objects in ruin.

In the case of walls of buildings in the form of permanent ruin, ground water and rain water have the greatest impact on the degradation processes.

Ground water

Water from the ground threatens not only the underground parts of the facility. It can be transferred to higher, above-ground parts of the wall due to the phenomenon of capillary rising. The capillary rising involves transporting water and slowly soaking areas of material that do not come in direct contact with the source of moisture. The capillary rising from the foundations may be the reason for the walls getting moist up to a few meters high. The height of the capillary rise depends on the structure of the material, primarily from its porosity and the structure of pores and capillaries. The height mentioned is inversely proportional to the diameter of the capillaries. This means that in microporous materials with a small pore and capillary diameter, the capillary rise is the highest. For thick walls erected from ceramic bricks, it can reach even several meters above the level of the water. In stone walls, the height of the capillary rise depends mainly on the type of rock. In the case of sedimentary rocks (limestones, sandstones) it is definitely the highest. In the case of igneous rocks, the capillary rise is minimal or does not even occur. This does not mean that in walls made of igneous rocks, or metamorphic rocks of an igneous origin, there is no phenomenon of the capillary rising. Due to the fact that a wall also consists of mortar, the water is pulled up to the higher parts of the wall by a network of joints.

Rain water

Rain water is the largest quantity in the total water balance in the immediate vicinity of the facility. It can cause the wall to get damp in a direct and indirect way. Direct moisture appears when the rain water hits the exposed elements (e.g., wall top, side surfaces). Dampness appears indirectly when rain water falls over the walls in the ground floor or the so-called splash water occurs.

The greatest damage is observed in the ground floor (no insulation) and on the top of the walls (in the absence of shielding elements). The flowing water also leads to damage to the face of the walls, this effect is particularly visible in walls of variable thickness. Movement of moisture in a wall in the first stage results in the dissolution of mortar binding substances and damage to the joints or their complete elimination. This process is mainly caused by rain water flowing down towards the ground. As a consequence, there is a reduction in the load-bearing capacity of the wall parts where the joints are missing. The next step is the systematic separation of the masonry material (brick, stone) from the wall.

Humid materials are subjected to accelerated destruction also due to the cyclical freezing and thawing of water contained in pores and capillaries. Water in the pores of materials and in cavities of the wall freezes and increasing its volume, which destroys the material. Degradation as a result of the so-called frost damage is particularly visible on the south-facing facades of facilities due to the repeated action of freezing and thawing during one season. Moistening of materials also accelerates the chemical corrosion of metal elements that may be in the walls.

The purpose of the test is to determine the moisture status of partitions in the facility. The determination allow to obtain information on the scale and range of moisture and they allow to determine the source of moisture. Determination conducted at various depths and heights provide information on the moisture distribution in the masonry structure.

Depending on the needs, the tests may: have cognitive character (scientific research), decide on

the scope of repair work (pre-design phase of renovation), inform about the possibility of embedding further materials (finishing works), or provide evidence (claim and court cases).

In Poland, the direct measurement (gravimetric, laboratory) is considered as the only reliable way to measure moisture content. Despite the simplicity of the weight moisture content determination and the availability of research methods, a whole range of activities related to obtaining reliable results remains a problem. Their credibility is influenced by the method of material sampling, depth and height of the sampling, the number of measuring points, and the interpretation of the results obtained.

The first problem is the method of obtaining material for testing. Sampling with boring devices is not recommended because of the drying of the material for testing. Based on the literature, hacking or using pipe punches is recommended. In many objects, both methods are difficult or impossible to apply. When sampling at larger wall depths, a large wall fragment could be damaged during the removal of the material. The use of pipe punches is limited only to the collection of samples at a shallow depth and applies to materials of low strength. When taking samples from a greater depth, the problem is to remove the pipe punch with the material from the partition. This can be facilitated by pre-drilling of the hole and driving a pipe of larger diameter at the location of the hole made. In this case, the sample should be taken after several hours from drilling. This time is necessary to equalize the humidity in the place of sampling.

The simplest way and probably the most commonly used (not recommended) is drilling and removal of drill cuttings for testing. This method entails an error related to the decrease in the value of the results obtained. During drilling, the drill bit warms up and the water evaporates. Depending on the drilling speed, the drill bit used (diameter and condition of the blade), and the material, the temperature in the hole can rise up to tens of degrees (according to the authors' research). Significantly smaller errors occur when using low-speed drilling or drilling rigs with crowns not cooled by water. For low-speed drilling, the amount of heat caused by friction is much lower than for high-speed drilling. The use of devices with simultaneous water cooling is excluded by the nature of the research, while non-cooled crowns are subjected to a rapid wear and their use is limited to low-strength materials.

Therefore, regardless of the drilling technique, when the material is collected for the moisture tests, drill cuttings are dried. The weight loss of a moist sample should be taken into account in the calculation of a moisture content.

Another important problem is the depth and height from which samples should be taken. Due to the fact that the distribution of humidity in a wall is not linear, differences in results should be expected at different depths. The question remains whether, due to the heterogeneity of the distribution, several samples should be taken from various depths, or one representative for the entire partition. Polish-language sources provide information about one sampling at different depths and a height of 0.5m above the floor level. Foreign sources recommend taking samples from three various depths (three depth profiles) and three height points on one axis. Depending on the approach, one or 9 samples can be taken within a small area of the partition.

Trying to limit the large number of samples taken and at the same time obtain the necessary information, the authors in their research take a minimum of two points on the axis, and the number of depth profiles depends on the type of the partition tested. Taking a minimum of two points at different heights allows to determine the amount of water rise in the walls above the ground level. In the case of cellar walls, it makes it easier to identify the source of water causing moisture. As a rule, samples are taken from the wall just above the level of the floor (inside the building) or terrain (outside), and at least one above the first one (e.g., at a height of 1 m).

Another problem during the research is the adoption of a reliable number of samples from the object. This number depends on many factors, and the most important ones include: the dimensions of the object tested, the method of its foundation, the basement surface, material and constructional homogeneity of the walls, the condition of partitions, and the purpose of the tests.

Based on the experience of the object moisture content tests, the basic principles of material sampling were determined:

- Samples should be taken from the depth of 1/3 - 1/4 of the thickness of the wall. The test material must come from the entire length of the hole.
- During sampling the material cannot be overheated.
- In order to determine the moisture distribution depending on the height of the wall, the test should be carried out on the floor level (inside the building) or terrain (outside), and at least one above the first (e.g., 1m high). In places where the height has been changed, it should be measured in each case.
- Cuttings should be sealed in a container and if it is necessary, to transported and stored in a refrigerator (if the moisture determination is carried out after a longer period from the moment of sampling). In the case of several days of research on the object, the samples can be frozen and transported to the laboratory in such a state.
- The openings from which the material for testing was taken, should be supplemented with a material compliant with the one taken from the wall.
- Additional photographic documentation of the places of sampling should be performed. This will allow to apply the test points to the drawing documentation.

The method of making the moisture content determination is specified in the PN-EN ISO 12570 standard „Hygrothermal performance of building material and products - Determination of moisture content by drying at elevated temperature”.

Before the drying process, the test specimens should be weighed to the nearest 0.1% of their mass. Then, the samples should be dried to a constant mass at the temperature specified in the relevant product standard. A constant mass is achieved when the change between three consecutive weighings performed within 24 hours is less than 0.1% of the total mass. The samples should be cooled in a desiccator and weighed after reaching a temperature of 30 °C to 40 °C with the same accuracy as described above. The samples are weighed before they are completely cooled down to minimize the re-absorption of moisture.

The weight moisture content is determined according to the formula:

$$w_m = \frac{m_w - m_s}{m_s} 100\% = \frac{m_{wody}}{m_s} 100\%$$

where:

w_m - weight moisture content [%]

m_w - mass of the moistened sample [kg, g]

m_s - mass of the sample to be dried to a solid mass [kg, g]

m_{wody} - mass of water in the sample [kg, g]

In most studies dealing with the problem of humidity research, there is (rightly so) information about the lack of standards specifying the acceptable moisture content of building materials. At the moment, the information supporting the interpretation of the results obtained comes from several different sources. The situation looks best when it comes to requirements for the substrata on which specific construction works are to be carried out. Information on these requirements can be found in the „technical conditions of execution and acceptance of construction works” or in safety data sheets, approvals, and certificates of embedded products.

When interpreting the results of weight moisture content tests of building partitions, the two tables below are helpful. The first of them comes from the expired standard PN-82/B-02020 „Thermal protection of buildings” and gives permissible values for the weight moisture content of masonry materials. The data provided indicate the humidity value in the so-called dry state and its maximum increase. In total, the value obtained only informs about the value at which the wall ceases to be „dry”.

Tab. 14th Permissible weight moisture content of materials in external building partitions (part of the PN-82/B-02020 standard „Thermal protection of buildings”).

No.	The type of material or partition	Humidity before the period of moistness [%]	Permissible humidity increase [%]
1.	Wall made of ceramic bricks	1.5	1.5
2.	Wall made of ceramic hollow bricks	1	2
3.	Wall made of silicate bricks	3	2
4.	Aerated concrete	3	4

More detailed information is provided in the second table. The humidity ranges and the description of the wall were assigned to the next humidity levels. The table was developed only for ceramic brick walls and for obvious reasons its automatic use for walls made of other materials is impossible.

Tab. 15th Humidity levels of walls.

Level	Weight moisture content [%]		Description
	Ceramic brick	Limestone with a porous structure	
<i>I</i>	0 - 3	0 - 4	Walls with acceptable humidity
<i>II</i>	3 - 5	4 - 6,5	Walls with increased humidity
<i>III</i>	5 - 8	6,5 - 10	Moderately moist walls
<i>IV</i>	8 - 12	10 - 15	Very moist walls
<i>V</i>	> 12	> 15	Wet walls

The simplest solution is, of course, the conversion of ranges taking into account the density of particular materials (the author included such a proposition for three other materials). The given ranges result only from simple mathematical calculations and therefore should only be treated as a proposal that facilitates the interpretation of the results obtained.

The report from the tests should include: the sampling method, the equipment used for collection, a description of the sample taken (type of material), the number of samples for individual storeys, heights at which the material was collected, date of collection, place of examination, date of testing, apparatus and equipment used in the laboratory.

Tab. 16th An example table of moisture test results

Test point	Place of collection	Height [m]	Moisture content [%]
...
...
...

The test apparatus should contain:

- A dryer capable of maintaining a drying temperature of at least 105 °C with an accuracy of ± 2 °C and a relative humidity of less than 10%; in the case of hot and humid air or low temperature of drying, it may be necessary to provide drying air to ensure proper relative humidity.
- A scale that allows weighing samples for testing with uncertainty of no more than 0.1% of their mass.
- A desiccator.



Photo 71. A laboratory dryer



Photo 72. A laboratory scale

4.4. Salinity tests

Water-soluble salts are among the most dangerous factors damaging building structures. It is quite common to find out that they are the cause of the greatest damage in the basement of a building. Their high concentrations can sometimes lead to complete destruction of building parts which are salinated. The carrier of salt in building materials is water, and damage occurs as a result of the salt crystallization processes during its evaporation. Therefore, salinity largely corresponds to places with high humidity. The most common salts occurring in buildings are: sulphates, chlorides, nitrates, and carbonates of sodium, potassium, calcium, ammonium, and iron. In terms of mineralogy, the most common salts are: halite, sylvite, bishofite (chlorides); nitronatrite, nitrocalcite, niter, nitromagnesite (nitrates); mirabilite, arkanite, epsomite, kiserite, thenardite, gypsum (sulphates); termonatrite, natron (Carbonates). In the object, presence of only one type of salt is extremely rare. In reality, we usually deal with structures with mixed composition.

From a chemical point of view, salts are substances formed as a result of an acid neutralization reaction with an alkali. The reaction of the salt depends on what substances were involved in the process of its formation. In the case of strong acid and base as well as a weak acid and base, it will be close to neutral. Salts may also have acid reactions with a strong acid and a weak base and alkaline in the reverse system. It should be remembered that these compounds can then react with building materials containing the corresponding acids and bases. From the construction point of view, the most important are salts that are readily soluble in water, so those in which it easily breaks down into ions. The chemical composition of salt is the factor responsible for the level of danger. It has a direct influence on the scope and intensity of destructive processes related to the presence of these compounds in the material.

Excessive salinity is a problem primarily of old objects that do not have insulation, and thus are exposed to constant contact with moisture. However, this problem may also apply to protected objects, in which the moisture protection was insufficient or the material used had high primary salinity. It should be remembered that water penetrating materials and then moving in them is full of impurities. Salts dissolved in it are also considered contaminants. The most important sources include salts:

- included in building materials,
- pulled up in a dissolved state from the ground,
- contained in atmospheric precipitation,
- introduced during maintenance and impregnation treatments.

Raw materials from which building materials are produced contain specific amounts of soluble salts. In addition, further compounds may be formed in the process of making materials and their incorporation. Quite large concentrations of building salts are found in cement, gypsum, and cal-

cium binders, but also in masonry materials. In the case of monumental buildings, large amounts of salt penetrate the walls together with moisture pulled from the ground. This mainly applies to nitrates and chlorides. Moreover, within the old walls there were often ditches with impurities and buildings housing livestock, in the ground there are large amounts of nitrates and nitrites. Decomposition of dead vegetation further increases the concentration of these compounds within the objects surroundings. The presence of chlorides may also be caused by the use of salt in the winter. The salt goes then with the water to the ground, or in the form of „slush” directly into the basement walls. The main source of sulphate salts is the reaction of materials with contaminated air, and the effect of the so-called acid rain. Rainwater along with dissolved acidic oxides present in the polluted atmosphere penetrates deep into bricks, stones, and mortars, enabling chemical transformations leading to degradation of the walls.

Also poorly selected methods and measures used in conservation works can be the cause of the secondary salinity of objects. An example of such works is cleaning of the facade with agents containing acids or bases.

The mechanism of corrosive salt action is based on chemical and physical processes, and the substance that determines the destruction processes is water. Salts as solid substances do not move automatically in the materials. Therefore, in the corrosive processes, those that dissolve very well in water take part. In the form of a solution they reach all the places where water is transported. Their accumulation occurs places where water evaporates. The phenomenon of salt movement is called the migration to the surface. The most dangerous processes associated with salts include: crystallization, hygroscopicity, hydration, increase in concentration, and change in the pH of the solution.

The destructive effect of salt is based primarily on the phenomenon associated with the crystallization and expansion of their volume. The resulting pressure is large and sufficient to cause cracking of the pore walls in the material, loosening of the surface layers and, as a consequence, causing their decomposition, scaling, cracking, and disintegration. For a large group of salts, the pressure is from a few hundred to well above 1000 atm. The forces accompanying the crystallization process are so great that after a few cycles even the most durable bricks, stones, and mortars are destroyed. Their impact is greater than that created by freezing water.

Destructive salt action can have multiple effects. With continuous transport of the salt solution, its crystallization takes place on the surface of the element. This poses a smaller immediate threat of destruction, but results in a significant deterioration of the surface aesthetics of the material. The salts on the surface of the material can crystallize in the form of stains, efflorescence, fluffy blooms, and glassy coatings. These forms depend on the type and amount of salt, as well as on the conditions under which the crystallization takes place.

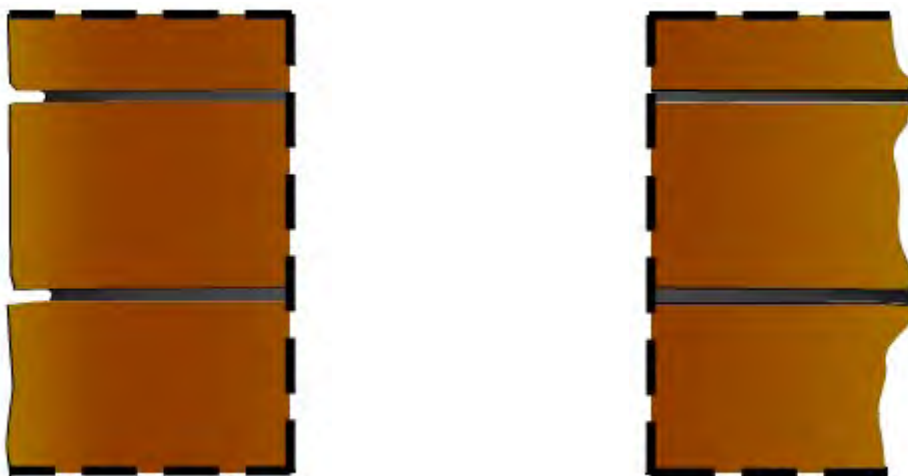

Figure 13. Salt corrosion of the wall surface with mortar weaker than the masonry material. **Figure 14.** Salt corrosion of the wall surface with mortar stronger than the masonry material.

In a situation where the speed of solution delivery is lower, moisture evaporates in the depths of the wall and crystallization occurs inside its surface layers. This course of the phenomenon causes much more severe corrosion of the walls. For some time, there are no visible effects of degradation, then there is more serious damage than in the first case. In this way, whole fragments of plasters or external surfaces of walls are damaged.



Figure 15. Salt corrosion at the interface between plaster and masonry



Figure 16. Salt corrosion inside the plaster layer



Figure 17. Salt corrosion on the surface of the plaster

The aim of the study is to determine the percentage content of main building salts (chlorides, sulphates, nitrates, and carbonates) in masonry materials, joints, and plasters of objects remaining in the form of permanent ruin. The knowledge obtained on the basis of the results allows for: assessment of the wall condition, forecasting further adverse changes, and conscious adoption of solutions aimed at counteracting destructive phenomena.

The most commonly used methods of analysis of wall's salinity include liquid chromatography, laboratory analyses, and ready-made chemical tests. The main advantages of the first one are: the possibility of simultaneous determination of up to a dozen or so ions in the sample, short analysis time, detection of very low concentrations, a small amount of sample needed for the analysis and a simple method of its preparation. A drawback, however, is the fairly high cost of the designation. In most cases, ready-made chemical tests are used in the study of salinity. The determinations are performed by titration or colorimetric methods using discs or color scales. During the tests, the load on the walls by: sulphates, chlorides, nitrates, less frequently carbonates, was determined. In addition, during the tests, the pH of the material being tested is determined.

The sampling technique depends to a large extent on the information to be obtained from the test results. The subject of determination may be the salinity of the wall itself or the wall and plaster. When testing the salinity load of a masonry wall with a secondary plaster, which during the renovation will be removed, only the masonry material should be sampled. If the historical plaster is to remain, both layers should be sampled.

It is important that sampling does not have a superficial character, because the salt content in the accumulation areas is often inflated. It is quite difficult to determine the optimal depth and height of sampling and the number of samples needed. Due to the uneven load of the wall with salts and the variety of bricks used, often the shifting the sampling site by several centimeters

gives different results.

The material for testing can be taken by bending or by drilling. Drill diameters and drilling speed, as opposed to moisture tests, do not matter, the material before testing is dried to a constant mass. It is important that the cuttings collected come from the entire depth at which the salinity determination was assumed.

There is no clear indication in the national literature how to interpret the results obtained during the tests. The problem of choosing corrective actions depending on the salinity examined is also not resolved. Only the PN-EN 206 standard contains provisions regarding the maximum concentration of building salts (chlorides and sulphates). However, they refer to concrete and reinforced concrete structures, so they do not apply in the case of the walls of historic buildings. In scientific papers and expert studies, the authors refer to foreign guidelines, primarily German and Austrian ones. In these studies, various levels or grades of salinity are given, often differing in terms of percentage salinity values within theoretically the same grade, or the number of introduced levels. Unfortunately, also in these studies, there are no unambiguous indications as to what corrective actions should be implemented. Below in the tables [Tab.1], [Tab.2], [Tab.3] three proposals of results interpretations obtained during the test are presented.

By far, the most popular in Poland is the table developed by the WTA, (German Scientific and Technical Working Group for the Protection of Monuments and Renovation of Old Construction, which deals with the protection and care of monuments and historical buildings), which classifies salinity in the form of grades. It distinguishes three load levels of building salts (low, medium, and high) for the three main salt groups.

Tab. 17th Salt load rates according to the current WTA 2-9-04/D instruction „Renovation of plaster systems”

Salts	Content in % (mass)		
	low	medium	high
Chlorides	< 0.2	0.2- 0.5	> 0.5
Nitrates	< 0.1	0.1- 0.3	> 0.3
Suplhates	< 0.5	0.5- 1.5	> 1.5

According to the Austrian Ö-Norm B 3355, there are also three salinity groups. In addition, depending on the grade, the document indicates the absence or necessity of taking corrective actions. For Group I, no preventive or remedial measures are needed. With the second level of salinity, corrective actions should only be taken in some cases. However, when the salinity in the facility evaluated is at the third level, corrective measures should urgently be applied.

Tab. 18th Classification of the salt load on the basis of Austrian Ö-Norm B 3355 standard „Walls drying”²²

Anions	Salinity in percent by mass		
	I	II	III
Chloride	< 0.03	0.03- 0.10	> 0.10
Nitrate	< 0.05	0.05- 0.15	> 0.15
Sulphate	< 0.10	0.10- 0.25	> 0.25

Another proposal to assess the salinity of materials is provided by the author of the publication entitled „Drying walls and basement renovation” - Frank Frössel²³. The author introduces five levels of salinity expressed in mmol of salt/kg with an additional description of each level. In the table, the salinity grades determine the collective values for all salts, which is not entirely appropriate

²² ÖNORM B 3355: 2017 03 01 Trockenlegung von feuchtem Mauerwerk - Bauwerksdiagnose, Planungsgrundlagen, Ausführungen und Überwachung

²³ Frössel F.: Osuszanie murów i renowacja piwnic, Warszawa, POLCEN Sp. z o.o. 2007.

due to the large differences in the harmfulness of individual groups.

Tab. 19th Levels of the salt load based on „Drying walls and basement renovation” by Frank Frössel²⁴

Level I	0 to 2.5 mmol of salt/kg	The wall construction shows traces of salt.
Level II	2.5 to 8 mmol of salt/kg	There is a slight load on the construction with salts.
Level III	8 to 25 mmol of salt/kg	There is a medium load on the wall construction with salts.
Level IV	25 to 80 mmol of salt/kg	There is a high degree of the salt load.
Level V	more than 80 mmol of salt/kg	This is an extreme salt load.

Summing up, irrespective of the chosen way of interpreting the results after the tests, only the percentage or mmol of salt/kg values of the salt load of the material can be specified. However, there is a lack of unambiguous answers to the question of how to counteract this phenomenon with a given level of salinity.

The report from the tests should include: the sampling method, equipment used for the collection, description of the sample taken (type of material), height and depth at which the material was collected, date of collection, place of examination, date of examination, apparatus and equipment used in the laboratory.

Tab. 20th Sample results of research.

No.	Height [m]	Depth [m]	Sulphates [%]	Nitrates [%]	Chlorides [%]	pH	Place of sample collection
1
2
3

The report should also contain sketches showing the collection points and photographic documentation.

5. Studies of historical plasters and painting layers

Investigations of mortars and painting layers are carried out by conservators-restorers of works of art, assisted by specialist research for physico-chemical analyses and instrumental studies. Test methods for plasters and mortars are practically the same.

The research is aimed at recognizing the decor and the historical material in terms of its construction and components used, as well as texture, colors, stratification analysis, state of preservation and damage with its reasons. The goal of most studies is to prepare guidelines for conservation projects.

The research is carried out in two stages:

- in-situ tests (including outcrops), in the course of these tests, sampling sites for laboratory tests are designated,
- laboratory tests (construction and composition of materials),
- microscopic analysis (optical, electron),
- instrumental analysis (DTA, XRD, FTIR, XRF, EDS),
- analysis of color schemes, e.g. painting (stratigraphy, binders, pigments).

5.1. Laboratory tests of mortars

Laboratory tests of mortars play an important role in determining the history of architectural monuments. Characteristics of historic mortars are based on research methods, such as: polarizing microscopy (MP), X-ray diffraction (XRD), thermal differential analysis (DTA/RGA), and scanning electron microscopy with EDS analyzer (SEM-EDS). All these methods require collection of a small amount of material from the facility. The choice of the right methods is, among other things, associated with the amount of material available for testing and the expected results - as these are destructive methods.

Originally, the method commonly used for mortar testing was classical quantitative chemical analysis, which did not always allow for the determination of the mineral composition of mortar, e.g., carbonates - a very significant and characteristic component, affecting, in a way, the type of mortar technology, they can occur as a binder and filler. Therefore, it was thought that microscopic examination of both slips and thin plates should be a necessary to supplement chemical analysis. According to the researchers' proposals, both methods - chemical quantitative analysis and microscopic analysis - should be accepted as a prerequisite in the study of a historic mortar. They should be a minimum, necessary to understand the composition and structure of the research material. They should be also the starting point for a broader research, allowing the reproduction of technology. The current progress in mortar testing methods does not indicate chemical analysis as a necessary method due to the low accuracy of the tests.

A significant part of the above-mentioned methods is the basis for the study of minerals and rocks, of which the method of microscopy in transmitted polarized light (MP) deserve special attention. These methods provide information not only about the phase composition of the material tested, but also relevant data about its structure and spatial relations of components included in the mortar.

Mortar testing is usually preceded by a visual assessment of the state of preservation and the building technique. On this basis, the places from which samples are taken for detailed instrumental analyses are designated. At this stage, the type of samples and the size of fragments to be test-

ed are determined, depending on the methodology of the research and the scope of the analyses. Adoption of a specific research methodology allows later to avoid a situation in which the sample taken turns out to be too small. At the outset, it should be determined which problems must be solved. This facilitates the selection of the appropriate research methodology.

In general, mortar samples are collected according to the indications of art historians and conservators. The selection of the place of sampling results usually from two principles; the first concerns the selection of plasters, whose original character is confirmed by archival documentation. The second rule concerns the sampling of various technological mortars used for e.g. stonework, precious stucco decorations, and architectural elements made of artificial stone.

All these methods require the collection of a small amount of historical material from the facility. The act of sampling is destructive, as it causes irretrievable loss of fragments of historical mortar. The choice of appropriate research methods is, among others related to the amount of material available for research and the results expected.

General principles adopted in the mortar study say that the material should be authentic, well-preserved and typical for the object. When starting sampling, the following rules should be observed,:

- apart from the visual assessment criterion, the selection of sampling sites should be supported, if possible by non-destructive testing results,
- a minimum number of samples must be taken, the number of samples from one room - not less than 3 multilayered samples,
- samples must have small dimensions (however, when determining them, the type and number of analyses should be taken into account). For mortars, sample of size not less than 10 cm³,
- method of collection - samples are cut out in the form of pieces (using a knife or chisel), all layers are taken, down to the ground,
- place of collection - in accordance with the general rules adopted (an additional assumption was the selection of elements easy to reproduce). Sampling points should be re-filled with mortar.

The type of sample analyzed has a significant influence on the interpretation of the results. The next important parameter is the size of the sample, which should contain the test material in an amount sufficient to obtain satisfactory results. When the sample size is insufficient and goes beyond the lower limit of the sensitivity of the method used, the test result is negative, despite the presence of the material sought. In a sufficiently large sample, the probability of recognizing secondary and even trace elements as well as the possibility of detailed classification increases.

5.1.1. Macroscopic examination

Macroscopic examination can provide the necessary information to understand different aspects of the original technique and the state of preservation. The „visual” observation may not provide precise information about the nature of the materials present, nevertheless it may be an essential method when it comes to the choice of laboratory tests and may be decisive in the interpretation of results. Visual tests are not expensive and can be carried out in situ (without the need for sampling). Applications are drawn immediately. The visual observation is a skill acquired solely by experience in the study of works of art.

Macroscopic analysis is the initial stage of mortar laboratory tests. It allows for classification of mortars on the basis of features visible to the naked eye and with a magnifying glass with low magnifications.

Macroscopic examinations include the naked eye examination and magnifying glass with an approximate magnification of 6-10x and max. 40x. In the first phase of the observation, all the samples are subjected to it, followed by fragments with particular attention to fresh fractures. The number of layers, their thickness, mutual adhesion, color, compactness, size and distribution of pores, crevices, cracks are determined. The hardness according to the five-point scale is determined: very hard, hard, quite hard, not too hard, brittle.

Photo 80 presents an example of the results of macroscopic analyses. As can be seen from the data compiled, mortars macroscopically differ mainly in the color of individual groups, although the color evaluation is quite subjective and a color scale should be used for comparative determinations. Other distinguished features such as hardness, surface quality and adhesion of the binder to aggregates in mortars also depend, to a large extent, on the investigator's subjective assessment. For this reason, macroscopic analyses should be treated as preliminary studies for more detailed analyses, including their usefulness in the preliminary mortar classification. In macroscopic observations, many of the important characteristics of a given material remain unrecognized, especially when the components are small in size.

5.1.2. Optical microscope investigation

Optical microscope studies combined with instrumental tests (DTA and XRD) are helpful in the chronological classification of mortars found in an architectural object. They make it easier to determine the typological groups of mortars characteristic for different phases of the construction of the monument, and identify stratifications originating from later conservation interventions.

The basic aim of the microscopic examination of mortars is the identification of mineral components both in the filler and in the binder. Identification of mineral components is carried out in transmitted, polarized light.



Photo 73. Polarizing microscope - Zeiss Axiolab. WBIA laboratory of Lublin University of Technology

Quantitative methods of microscopic analysis allow the determination of individual mineral components with an accuracy of 1% in relation to chemical analysis. Such accuracy is sufficient for a good characterization of a given mortar. The materials can be analyzed using a microscope for two types of microscope preparations: powder formulations and thin plates (microscopic sections).

Powder formulations allow to recognize the qualitative and quantitative composition of the material tested. Due to the destruction of the structure and texture of the material during powdering, however, they do not give the possibility to determine the distribution of mineral grains in the binder and their mutual contacts.

More labor-intensive preparation of preparations in the form of thin plates is more beneficial. Thin plates are prepared by grinding a piece of a sample onto a spinning disc sprinkled with abrasive powder. After sticking with the Canadian balm to the glass and sanding the plate to a thickness of 30-50 microns, the preparation is fixed by covering the plate with a thin layer of balm and a coverslip. The thin plate is a preparation that allows to recognize individual components, but also to trace the size and condition of grains (structure), and the distribution of individual components and their degree of filling (texture). Determination of these three factors: structure, texture, and composition - allows for precise characterization of the material and thus enables conducting strict comparative studies.

5.1.3. Quality microscopic analysis

In order to obtain the most accurate characterization of the examined microscopic material, first and foremost, general features are defined:

- mortar texture - the degree of grain distribution in space and the degree of space filling,
- mortar structure - size, shape, degree of coating of the grains.

In determining these features, the principles adopted in petrography are used. When defining the qualitative composition of mortars, two main components are distinguished:

- filler
- binder - a connecting substance.

Additionally, in the final analysis process, the distribution, shape and size of the pores are determined.

The most common filler in mortar is sand. Considering the large diversity of sands depending on their structure, sedimentation and mineral composition, its exact characteristics may be one of the basic features in the comparative analysis of mortars within one object or assembly. With this in mind, the following groups are identified when analyzing sand:

- main constituents - which prevail in terms of quantity and are decisive for sand classification,
- side components - fewer, clearly influencing the classification,
- accessory components - which occur sporadically, in small amounts and are not relevant for the basic sand classification.

In the microscopic examination of mortars attention is paid to the size of the grains, giving an estimate of their maximum, minimum and most common dimensions of the largest diameters. Data can be given by measuring the largest diameter of 200 grains. The structure determines the size of individual components, the degree of grain development and their shape. The criteria of structures used for sedimentary rocks are used also for mortars. When considering the size of grains, the following structures are distinguished:

- conglomerates (grains with a diameter greater than 2mm),
- sandstones (2mm to 0.02mm),
- mudrocks (grains less than 0.02 mm).

The second feature to which attention is paid is the degree of roundness (rounding) of the grains, in which case an approximate number can be given, or by a more accurate analysis, the number after measuring (of at least 200 grains). There are four degrees of grain roundness:

- very good degree of roundness - they represent round, oval grains that do not show any sharp bumps on their surface,
- good - rounded grains, but they have some surface roughness, only corners are rounded,
- slightly covered - have a lot of surface roughness, only the corners are rounded,
- sharp-edged - the grains have sharp, unrounded edges.

During the research, attention is also paid to the possibility of occurrence of a filler other than sand whose presence could have an impact on the mortar technology. Previous research has proved that in old mortars (mainly limestone) there was also found a carbonate filler, baked clay, crushed ceramic material, and organic substances such as: straw, flax fiber, hemp, fur, fragments of charcoal. These additives were used to obtain mortars with appropriate properties.

For the above reasons, the analysis of the filler should also include the indication of the type of:

- organic additives,
- ceramic additives,
- other additives (carbonate debris, burnt clay, etc.).

If carbonate filler is found, on the basis of microscopic examination of their features (shape, crumb size, ratio to binder and other mortar components, optical properties) the following types of particles are distinguished:

- crumbs of carbonate rocks, most often dumped, with clear contours, size similar to other sand components, being a natural admixture of sand acting as a filler,
- sharp-edged, with distinct contours, of different or equal size, crumbs of crushed carbonate rock, added to the mortar to improve its properties,

- crumbs with irregular, often oval-shaped, usually exceeding by several times the size of the remaining components of the filler. These are fragments of not entirely burned limestone, which has been fragmented during the preparation of the mortar.

The binder - a mass connecting the filler grains. In the case of lime mortar, it was originally a slaked lime (calcium hydroxide). As the mortar ages, calcium hydroxide becomes calcium carbonate. The degree of development of calcium carbonate crystals in mortars is different. It seems to be a rule that in mortars, calcium carbonate microcrystals are larger than those found in younger mortars. The ratio of binder to the amount of bonded grains may be different. In some cases, there is little (pore or contact binder), in others the grains are surrounded on all sides with a binder („floating” in the binder) - a basal binder.

Microscopic analysis of binders includes the determination of the:

1. Quality composition
2. Degree of crystallization:
 - cryptocrystalline - in which even at the highest magnifications it was impossible to distinguish individual grains,
 - microcrystalline - in which the crystals reach a size of several thousandths of a mm.
3. Type (nature) of the binder:
 - contact (binding) - whose quantitative share in the mortar is small; it is only visible between the filler grains,
 - contact-pore - occurs in a small amounts between the grains and fills free spaces (pores),
 - basal (basic) - the nature of the background: filler's grains surrounded on all sides, they do not touch each other.
4. The nature of reactions between the binder and the filler components.

5.1.4. Quantitative microscopic analysis

For the full characterization of mortars, determination of variables in various mortars of the amount of binder and filler, the micrometer thin plate analysis based on the Rossival and Delesse's principle is performed, according to which the linear ratios of grains correspond approximately to their volume ratios. After measuring about 300 grains, the grain dimensions of the various components are summed up, and then they are converted into volume percentages. Quantitative analysis of mortars can be done using the „Eltinor” integration table, which allows automatic adding up of the grain sizes of 8 ingredients in an automatic sliding preparation. The results of the quantitative analysis are the basis for calculating the ratio of the binder to the filler and thus for reconstructing the approximate, initial composition of the mortar.

Test report

Microscopic tests include:

- qualitative analysis,
- quantitative analysis,
- microphotographic registration

The components included in the binder are measured, e.g., calcite, microcrystalline calcium carbonate aggregates, iron oxides, and aggregate components: primary limestone crumbs, gypsum crumbs and sand, and, additionally, the pores. The results are given in percentage by volume, assuming the sum of ingredients in the sample as 100%. Microscopic observations of thin plates with a thickness of approximately 30 μm are carried out using a polarizing microscope equipped with a digital camera, by which the photographs are taken. On the basis of the observations, the phase composition of the binder and filler is determined, the textual characteristics of the samples are observed, and the components are estimated.

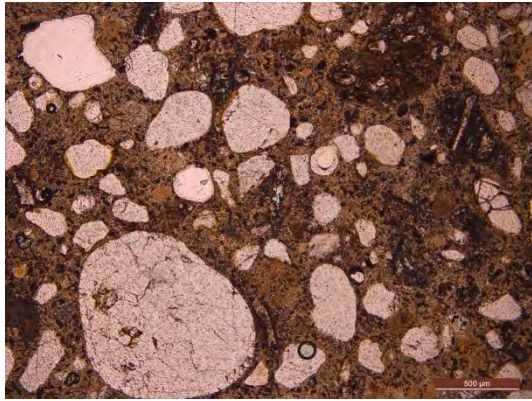

Photo 74. Microscopic image of a lime mortar sample in polarized light (1 polarizer)

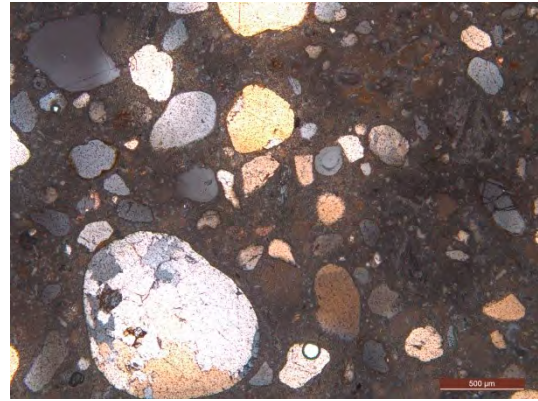

Photo 75. Microscopic image of a lime mortar sample in polarized light (2 polarisers, crossed)

Microscopic images of thin lime mortar samples in polarized light, with one and two crossed polarisers. The photographs show a micro and crypto crystalline binder of a basal nature. The mortar has a sandstone structure and a random texture.

5.1.5. Scanning electron microscope studies (SEM) and analysis (SEM-EDS)

The scanning electron microscope (SEM) is used to study the microstructure of samples taken from historical objects. The usability of the microscope results from the possibility of achieving a maximum magnification of 300,000x.

The scanning electron microscopy allows obtaining information on mortar degradation. The conducted analysis facilitates the observation of microcracks, changes in porosity, it facilitates the identification of fungi, molds, bacteria, etc. It gives the opportunity to determine the size and form of minerals present in mortars, it allows to study and register the texture of polychrome layers and stratifications.



Photo 76. Scanning electron microscope with a detector - Quanta 250 FEG by FEI company, EDS detector by EDAX. WBIA laboratory of Lublin University of Technology

The sample for examination in an electron microscope requires prior treatment. The size of the preparation is limited, which should not exceed the dimensions of $\varnothing=10\text{mm}$ and thickness $h=3\text{mm}$. A sample of this size is placed on a special preparation table, and glued with a suitable adhesive. Then conductive tape is glued to the edges, which enables better conductivity of the electric

charge from the sample tested to the preparation table. In the case of materials characterized by high resistance, in which it is difficult or impossible to quickly discharge the load from the surface tested, to improve the conduction conditions, a thin layer of carbon or gold is sprayed onto the surface of the product (in high vacuum).

The electron beam can be directed at the appropriate point, precisely tilted along a specific line or it can scan a selected area of the sample surface. This allows for performing point, line or surface analysis.

The surface „mapping” analysis facilitates the location of zones in which certain elements will be found; the linear analysis indicates their local distribution. These analyses give qualitative and semi-quantitative information about the distribution of individual elements, the point analysis enables their quantitative determination in selected micro-areas.

The SEM-EDS technique facilitates non-destructive testing of the chemical composition of individual layers present on cross sections of mortar samples. Fragments from the center of a fresh fracture of the sample are taken for examination in the electron microscope.

The description of the fragment selected should contain the following information:

- morphology of binder components, the size of individual elements or clusters, and description of interconnections,
- quality and distribution of air pores,
- descriptive characteristics of mutual contacts between the aggregate and the binder.

The description of the preparation should specify the structural elements present in a given sample, taking into account their morphology and size as well as the nature of their mutual contact, elements with the same morphology and differentiated ones. It should be noted which elements are predominant in the preparation. Bearing in mind that the surface observed in the best case is about 2mm², for each sample a minimum number of observations should be made on 3 micro samples taken from the correct sample. To facilitate the possibility of comparison of test results (SEM) for different samples, it is convenient to make photographic documentation of specific areas at fixed magnifications.

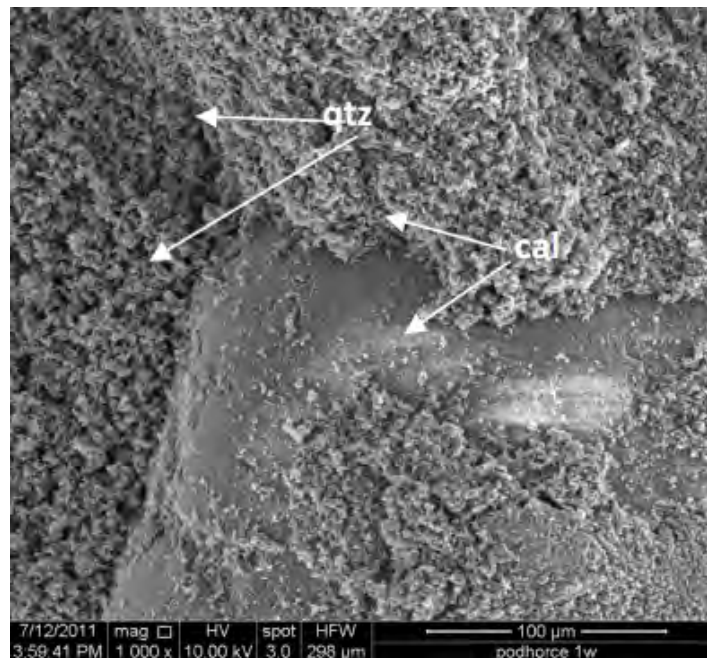

Photo 77. An image of the fracture of a lime mortar sample (SEM 800x) shows a porous compact mass of the lime binder (cal), in which few individual larger quartz grains are visible (qtz).

The EDS analysis of lime mortar samples shows the presence of mainly silicon oxide derived from quartz, as well as calcium oxides and sulfur, derived from calcite and gypsum. In smaller amounts, oxides of magnesium, aluminum, and potassium are present

5.1.6. Derivatographic study - differential thermal analysis (DTA)

Differential thermal analysis (DTA) is a research method in which the exothermic and endothermic thermal effects occurring in the system under investigation are detected, which accompany physical or chemical changes, and the change in the sample mass. This method allows detection of substances that are combustible (e.g., addition of charcoal) and substances subjected to thermal decomposition (e.g., calcium carbonate, magnesium carbonate, dihydrate gypsum).

The test performed with the aid of DTA allows to identify the crystalline phases of the tested samples, to evaluate the quality of lime used for the mortar and the course of its binding and hardening processes. The method is useful for preliminary tests in order to select samples for detailed research, e.g., microscopic and XRD tests.

A mortar sample is crushed in an agate mortar. The test sample, together with the reference substance constituting the reference system, is heated in the oven under the same conditions. On the basis of the measurement of the temperature difference between the sample and the reference system, thermal transitions can be recorded during linear heating.

Differential thermal analysis is based on the measurement of changes in physical and chemical properties of the material tested, depending on the temperature. The measured quantities are energy, mass or volume.

The DTA method allows for a full interpretation of the processes related to phase transitions, decomposition, chemical reactions, etc. However, it only allows approximate assessment of the quantitative composition of the substances present in the test sample.

By performing differential thermal analysis it is not possible to determine what kind of a gypsum binder was used to make the mortar - whether slow or fast binding gypsum binder - because the final product of the hardening reaction of these binders is always gypsum (sulphate dihydrate). Moreover, thermal analysis does not give answers about the presence of anhydrite in a mortar, because no thermal effects of this material are observed on the DTA.

5.1.7. X-ray diffraction test (XRD)

The X-ray diffraction is commonly used as a supplementary method in mortar studies. It allows for precise identification of many compounds with a crystalline structure (e.g., quartz, calcite, clayey materials).

The technique enables both qualitative and semi-quantitative analyses. The intensity of diffraction lines for a given component in a mixture depends on its quantity in the sample tested.



Photo 78. The X-ray diffractometer - X'pert PRO MPD by Panalytical. WBiA laboratory of Lublin University of Technology
The XRD measurements of historical materials are made on powdered samples, the mass of sam-

ples to be analyzed is several milligrams. The sample is grated in an agate mortar.

The X-ray diffraction (XRD) is a method used to study the structure of a substance. In the case of X-ray diffraction, each center becomes the source of a secondary spherical wave with an amplitude usually dependent on the angle of diffusion. If distracting centers are a regular spatial structure, e.g., a crystal lattice, interference of distributed waves at individual centers takes place (the so-called interference reflection), causing creation of diffraction-interference images.

In this method, knowing the length of X-ray radiation, it is possible to determine the lattice constants specific for specific crystals and the type of structure, based on the position of diffraction maxima. Using the X-ray diffraction on crystal lattice networks, bent beams are recorded on photographic film or by means of counters - the ionizing radiation detectors. The diffraction images obtained in this way are called diffractograms. This technique provides a lot of valuable information about the crystal structure and phase composition of mortar materials.

The technique is used to identify the crystals present in the sample and its phase composition by comparing the resulting diffractograms with the patterns cataloged in specialized libraries.

Diffractometric analysis may be of a qualitative nature, the content of individual components in the sample can be described based on the intensity of reflections from the identified phases. Usually, the following determinations are taken: +++ - dominant component, ++ - present ingredient, + - trace-present ingredient, ? - a presumed ingredient. Analysis of diffractograms allows the identification of ingredients.

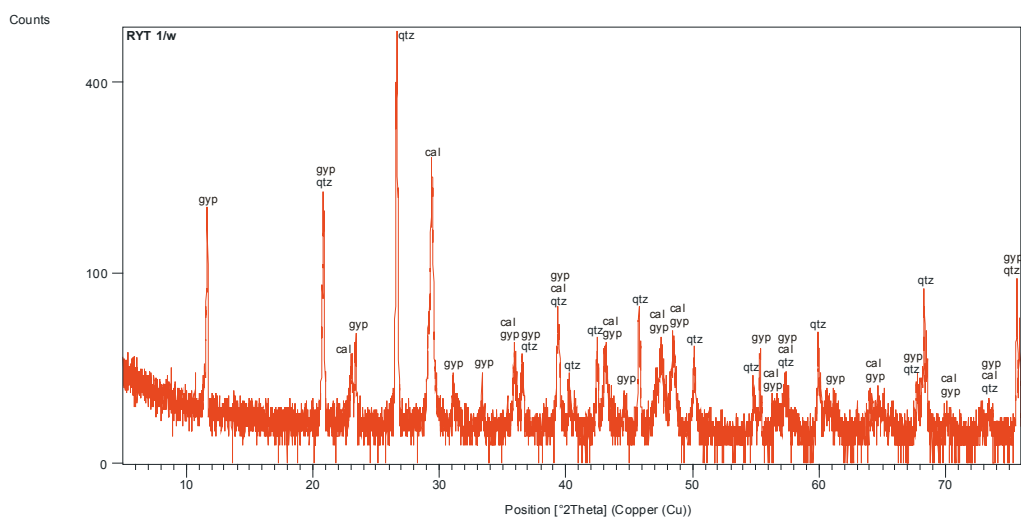

Figure 18. The X-ray diffractogram of a mortar sample. The X-ray analysis of the mortar sample shows that the most intense reflections come from quartz - qtz (+++), which is the main component of the filler. Subsequent identified mineral phases that give strong reflections are calcite - cal (++) and gypsum - gyp (++) , which are components of the binder.

5.2. Laboratory tests of painting layers

The identification of the materials from which the polychrome was created and the recognition of the technique of making all the chronological layers often allows to distinguish the authentic and secondary layers, and to determine the history of the object. A significant role in dating should be attributed to pigments that were used at specific time intervals. Recognizing the technique of making decorative painting can help in determining the chronology of the entire object. Studies on the technique of a polychrome making should be supported by the studies of art historians (analysis of the form, style, iconography, development of historical sources).

5.2.1. Optical microscope examination

The optical microscopy is the most commonly used in the study of painting layers and identification of pigments and adhesives. Microanalytical studies allows to perform analyses on a very small amount of historic substance (a few milligrams). The results of characteristic reactions are observed under the an optical microscope at low magnifications (30-60x). The advantage of these tests is the simplicity of implementation.

Microscopic analysis of cross-sections of paint layers enables determination of the amount, color, thickness, and structure of individual layers. Stratigraphy shows the technique of painting, but also provides a lot of data about the state of preservation of polychrome, as well as the occurrence of secondary layers. The microchemical and characteristic reactions are mainly used to identify pigments, less often water-soluble salts or corrosion products.

Sinking samples and making polyfoils. This is the stage of preparing the material for further visual and microchemical analysis. The test sample is embedded in a synthetic resin, and after a certain time as the resin hardens, it is subjected to a mechanical treatment (grinding) until a clear cross-section is obtained through all the painting layers. For a better effect, in the next stage, the sample is polished on a special wet polishing machine, at the same time removing the remaining dirt from its surface. The research material prepared in this way gives the possibility of further microscopic analysis.

Making colorful photographs of stratigraphic sections of painting layers. This method is used for the initial identification of pigments, binders and organic substances originating from conservation interventions.

In the course of microchemical analysis, the sample is exposed to an acid or base. Identification reactions are based on the formation of characteristic crystals, colors and on the emission of gas. They occur in ionic solutions of dissolved samples. The microchemical reactions are carried out on microscope slides or on paper strips. Basic microanalytical tests of samples are carried out in the following stages:

- at the outset, a careful observation of the fragmented sample should be carried out under the microscope in order to get acquainted with the structure and appearance of the materials tested. At this stage, fragments destined for microanalysis can be separated,
- the sample should be primed with an acid or base solution, and after observation under a microscope, it should be warmed to dissolve and dry,
- the dry residue should be dissolved in acetic acid or water and primed with a suitable reagent,
- the effects of the reaction under the microscope, in the light, dark field and in the transillumination mode should be observed.

The advantages of microchemical and characteristic reactions are: low cost and relatively good sensitivity. The main objection to this research is the significant use of material, caused by the necessity to perform a series of analyses for the presence of individual groups of substances or individual compounds. However, analyses of this type are useful to confirm or deny the presence of individual substances predicted in the sample.

UL. GRUNWALDZKA 5, ELEWACJA PÓŁNOCNA, GZYMS PODOKIENNY



Na elewacji północnej budynku przy ul. Grunwaldzkiej 5 zachował się biegnący w połowie wysokości lica ściany gzyms. Pobrano dwie próbki. Pierwsza zachowana historyczna warstwa była w kolorze białym.

ODKRYWKA NA GZYMSIE PODOKIENNYM



PRÓBKA NR 1

Historyczne warstwy na gzymsie, elewacja pn., od najstarszej:
1. jasnoniebieska; 2. zielonkawo-ruda; 3. biała; 3. zaprawa mineralna;
4. żółta; 5. piaskowo-żółta



PRÓBKA NR 6

Historyczne warstwy na gzymsie, elewacja pn., od najstarszej:
1. biała; 2. zielono-ruda; 3. jasnoniebieska; 4. zaprawa mineralna (?);
5. żółta; 6. nawarstwienia; 7. piaskowo-żółta; 8. piaskowożółta

Photo 79. The micrograph of the cross section of the painting layer on the plaster in visible light shows the presence of the following layers: 1 light blue, 2. greenish red, 3. white. 4 mortar, 5. yellow, 6. sandy yellow.

5.2.2. Scanning electron microscope examination (SEM)

The technique (SEM-EDS) enables non-destructive testing of the chemical composition of individual layers on cross-sections and surfaces of polychrome samples.

The test methodology, analogous to that used for mortar, is described in the section on electron microscope investigations of mortars.

Research using a scanning electron microscope coupled with an electron diffusion electron microprobe EDS (SEM-ESD). The EDS microanalysis enables the creation of elemental maps, showing the distribution of elements in the area of sample under investigation.



N K

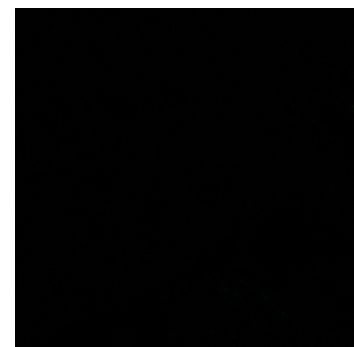

Al K

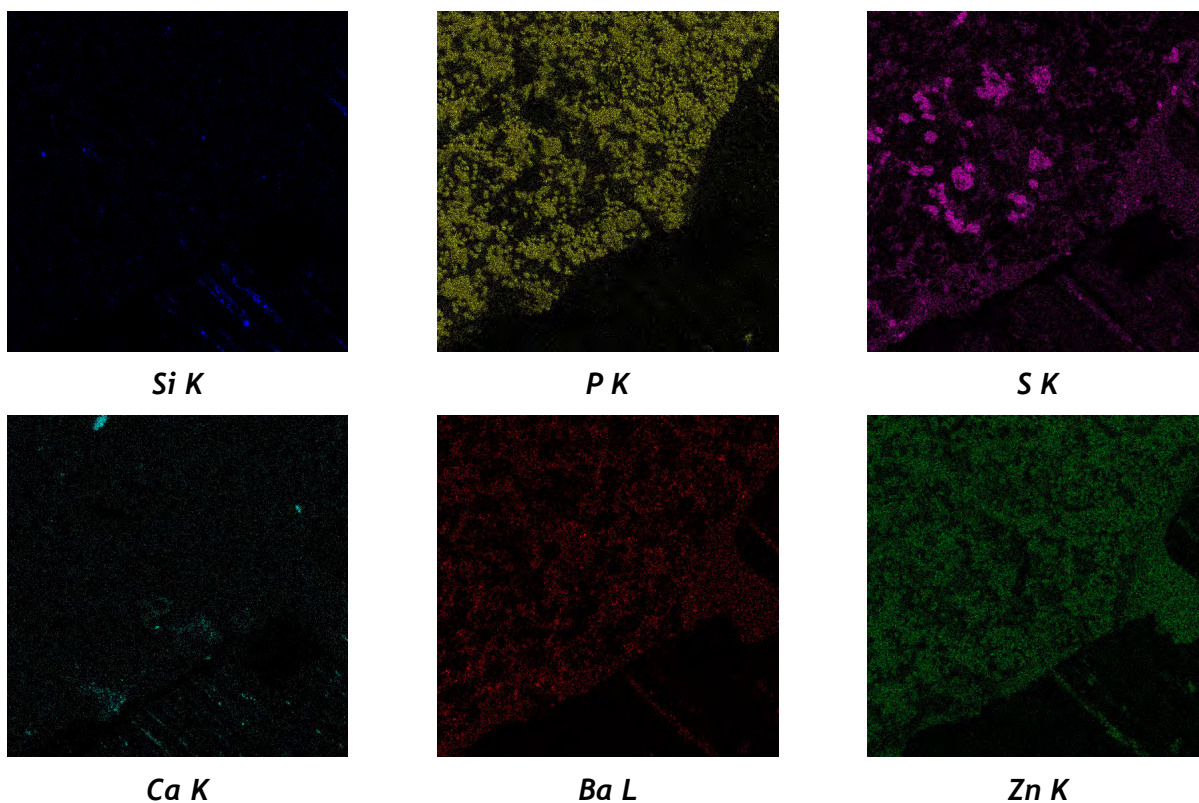

Photo 80. Elements distribution map (SEM-EDS). The results of paint surface tests. The first picture shows the image of electrons dispersed from the area of the surface analyzed (SEM-BEI). The remaining photographs are images of density distribution of specific elements on the surface of the sample (SEM-EDS).

5.2.3. Research on organic compounds: pigments, dyes, binders in Fourier analysis

The main benefits of using the FTIR spectroscopy (Fourier Transform Infrared Spectroscopy) lie in the possibilities of chemical analysis in the space of an image (the micro-FTIR, mapping or imaging), simultaneously and on the same sample, both organic and inorganic materials, regardless of whether they have a crystalline or amorphous structure. It is the correct analytical method for the identification of small, microgram samples of complex mixtures (organic and inorganic). It allows to distinguish between chemical similar substances (i.e., drying oils, organic waxes, minerals, pigments, etc.). It allows to detect, in the sample, the presence of both crystalline and amorphous compounds. It simplifies interpretation of spectra thanks to libraries of standard reference spectra and other libraries.

The FTIR microscopy is a suitable analytical method for characterizing inorganic layers and organic materials and can be used in the laboratory for surface degradation tests as a non-invasive method.

Infrared spectroscopy is used to analyze the composition of painting layers. The technique is used for the chemical identification of both organic compounds (binders, dyes, varnishes, adhesives, outer layers, etc.) as well as inorganic ones (pigments, corrosion products, salts, etc.)

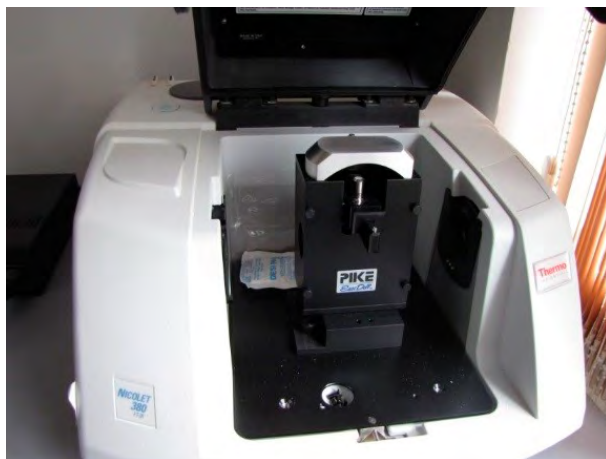

Photo 81. The infrared spectrometer - FTIR Nicolet. WBiA laboratory of Lublin University of Technology

Analyses using the FTIR spectrometer require micro-samples taken from the object. Therefore, this technique should be treated as micro-invasive. Solid samples, such as polychrome layers of mural paintings, are prepared by pelleting. A weight of the powdered sample is mixed with the KBr powder and is pressed under pressure of 6-12 atmospheres. Since potassium bromide is transparent in the range of $400\text{-}4000\text{ cm}^{-1}$, the absorption bands measured are derived from the test substance.

The main benefits resulting from the use of the FTIR spectroscopy lie in the possibilities of chemical analysis in the space of an image (the micro-FTIR, mapping or imaging), simultaneously and on the same sample, of both organic materials (binding media, varnishes, adhesives, coatings, consolidators, etc.) and inorganic materials (pigments, corrosion products, salts, etc.) regardless of whether they have a crystalline or amorphous structure.

The result of the infrared analysis is a spectrum which is a graph of percentage transmission/absorption of a sample as a function of length (cm^{-1}). In the case of complex systems, the spectra can sometimes be difficult to interpret, as it happens when the transmission/absorption spectra of the components overlap. For this reason, an initial selection of the particles analyzed may be helpful.

The spectra obtained from the sample analyzed undergo a certain mathematical operation - the Fourier's transformation. Then, the measurement curves developed in this way are subject to interpretation - identification of organic compounds found in the sample: pigments, dyes, and binders.

5.2.4. Spectrometry test - the X-ray fluorescence (XRF)

The X-ray fluorescence (XRF) is one of the most commonly used analytical techniques for analyzing the elemental composition of historic materials. The requirement of minimal interference in historical matter has contributed to the construction of many types of small portable spectrometers with which XRF in-situ analyses can be performed.

The XRF technique is widely used for testing paint layers (pigments), metals and their alloys, ceramic and glass materials, corrosion products.

The XRF spectrometers most often allow for the identification of elements with atomic numbers between 11 and 92 (from Sodium Na to Uranium U). The identification of lighter elements with atomic numbers from 11 (Sodium) to 21 (Scandium) should be performed in vacuum or helium atmosphere.

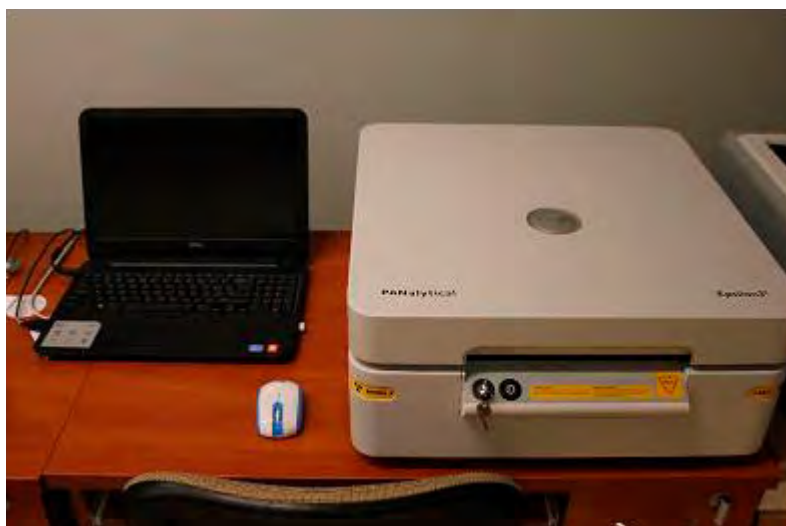

Photo 82. *The Epsilon 3 spectrometer by Panalytical. WBiA laboratory of Lublin University of Technology*

The XRF technique uses X-rays in the area between 5 and 10 Å, which irradiates the material to be examined. The X-rays emit electrons from the internal electron shells of the atoms. The re-filling of these shells is accompanied by the emission of fluorescent X-rays (this phenomenon is used to analyze the elemental composition). The fluorescence emission lines are marked with the symbols K, L, M ... depending on which of the atomic shells of the atom are filled as a result of fluorescence transitions. The energy of photons of the selected fluorescence emission line depends on the atomic number of the excited atom, which is why it allows its identification.

The recorded radiation spectrum is characteristic for a given atom. Spectral lines on the spectrogram indicate the presence of particular elements in the sample analyzed - this analysis is called qualitative, and from the intensity of these lines a quantitative analysis can be performed.

6. Good and bad examples of conservation of ruined sites

To help readers to recognize at first sight the presented category of intervention through the cases-study, it is provided a red table for **bad practices** and a green table for **good practices**.

Clock Tower of Mestre (Italy)

Name	Clock Tower of Mestre (Italy)
Location	Piazzetta Edmondo Matter - Mestre, Venice. Veneto, Italy.
Heritage	<p>The Clock Tower of Mestre or Torre Civica, dates back to the 13th century. It represents the only surviving testimony of the towers (over fifteen of them) that developed along the defensive walls of the ancient Castle of Mestre (better known as Castelvechio and Castelnuovo). It is equipped with a clock dating back to the sixteenth century and retains a city gate, the door of the Loggia (Porta della Loza), now half-hidden by a building of a later period. The new military techniques led to the demolition of the walls in the eighteenth century, too weak to resist enemy attacks. Between the nineteenth and twentieth century the building underwent two restoration interventions.</p> <p>With the first restoration, three passages were opened on the ground floor, to make a portico, and two small windows on the west side; the turret that contained a bell placed on the roof was demolished, the merlons were built and a new mechanism for the clock was installed. Whoever was responsible for making it work could use the tower rooms as he pleased; Consequently, for a long time it was used as a warehouse, coffee shop and private home. Between 1848 and 1849 it was a watchtower for the Austrian army. During the second restoration the remains of the ancient frescoes that covered the external walls were removed and once again the roof was fixed and the clock that did not work was replaced. At the beginning of the twentieth century two small windows were opened next to the clock face facing the Piazza, which was to indicate the hours, like those of the tower of Piazza San Marco. A few years later the idea of turning the tower into an aqueduct was advanced. During the Fascist period, black brigades met within its walls, whose political propaganda remains in the partially visible frescoes on the ground floor. Until 1950 it was rented out and then the City of Venice used the tower as city archive. In 1976 a strong earthquake put a strain on the structure and for this reason it was emptied of the archive waiting for the umpteenth restoration.</p>
Restoration	<p>The restoration project of the historic Medieval Tower of Mestre - inaugurated on September 28th 2003 - bears the signature of Guido Zordan. According to the architectural design by Arch. Guido Zordan, the static behavior of the tower and the deterioration conditions were checked in order to plan better conservation actions. Also, the static behavior of the tower was evaluated, with the insertion of the new steel structure of the flights of stairs designed to reach the top. In ancient time the tower was an open passage in the city walls, a "tower-door" that allowed and regulated the daily human flow linked to the needs of the population in a continuous exchange between the village and the countryside. Originally, it</p>

	<p>was a military defense construction, but it also had civil functions as a door that connected it to the Piazza and the Via Palazzo, with which it constitutes an urban system called “space of relations”. The restoration gives the tower new meaning for the civil and cultural life that takes place around it. An external wooden and steel staircase, modeled on medieval examples but conceived as a path, continues inside to the last level, the one of the clock. Never has a work been so praised and criticized, at the same time, as this staircase. From the beginning - the project was presented in 1999 - that work raised numerous criticisms and even a Committee led by prof. Mario Berengo, that even enlisted the architect Paolo Portoghesi, was established for the demolition of the staircase. But nothing has ever been done.</p>
Conclusion	<p>This restoration work, as much appreciated as criticized, above all for the insertion of the newly designed staircase, if we observe the environment in which it is located, certainly has merits and can assume in itself the expressive synthesis, in a modern way, of a staircase and a drawbridge. But the place where it is located, the space it occupies and its encumbrance alter the pre-existing equilibrium.</p> <p>Certainly, in the Middle Ages, there were no walls or towers without a staircase. At that time the staircase led to the wall trenches (now non-existent) and not directly to the tower. So the support on which the staircase should be placed is lacking, there is no reason for which the ladder should exist, which is why, according to many, the new staircase should not even exist.</p> <p>The inside of the medieval tower has been completely emptied and cleared of the old structures and everything contained in it. The walls are bare (only some anchor marks remain).</p> <p>No traces of the characteristic wooden stairs and medieval walkways remain, and a new, cumbersome, oppressive and heavy structure has been anchored with iron beams.</p> <p>Regarding the contents of the Tower, there is no trace of the old clockwork.</p>
References	<p>https://www.comune.venezia.it/it/archivio/9228</p>



Photo 83. Clock Tower of Mestre. View from Piazza Ferretto²⁵

²⁵ https://www.bolinaingegneria.com/assets/195/default_ID_TORRE_MESTRE_DA_PIAZZA_FERRETTO.jpg

Name	Castel of San Michele in Ossana (Italy)
Location	Ossana, Italy.
Heritage	<p>The castle of San Michele di Ossana in Valle di Sole (western Trentino) was acquired into the provincial public patrimony in 1992, from private a property.</p> <p>The building’s genesis, which recorded an almost reconstructive phase in the early decades of the fifteenth century, and that of degradation, with a probable decisive anthropic intervention, both strictly derived from the cited context, have produced a singular condition of the monument, for these reasons unique, in which naturalness and artificiality are continuously compared, with different degrees of ruin</p> <p>The castle stands on the rocky cliff that separates the village of Ossana from the river Noce to the confluence between the two valleys.</p> <p>The imposing tower, the best preserved building in the castle, touches at the highest point the first polygonal wall structure, to which in ancient times, on the inside, adjoined large residential buildings, of which only masonry remains. Part of what was the southern wall of the old church of San Michele has remained incorporated into the defensive curtain, to indicate the antecedence of religious construction with respect to the former walls.</p>
Conservation works	<p>The task of drafting an overall conservation project entrusted by the provincial administration to prof. Francesco Doglioni had a dual purpose: the first, of a design nature, with the aim of preserving the specific asset for the purpose of visiting and sightseeing; the second, methodological in nature, with the aim of identifying a method applicable in the conservation and recovery of the ruins, both in the analytical phase, in the design phase, and in the execution phase and intended the ideation and conduct of the interventions preordered directly by the Superintendency for architectural heritage and those presented by third parties, for which the Superintendency performs the functions of high surveillance or for which it exercises authority for authorization and control. This method would have allowed the collection of documentary and material documentation data, finally comparable, thus reinserting the individual data in a wider context, organizing them within a project for knowledge.</p> <p>For this purpose the architect Giorgia Gentilini was entrusted with the task of stratigraphical reading of the risers , based on the findings, and in this sense an intense archaeological investigation was set and conducted, laying the foundations for a profitable institutional relationship, based on interdisciplinarity rather than on simple control of phases of competence.</p> <p>Overall, the project aims to combine conservation of the wall elements with methods aimed at preserving the character and status of each part, and to promote a greater understanding of the whole castle, refined with the partial practicability of places that were inaccessible. It was also proposed to strengthen its visibility from the surrounding territory, also through interventions into vegetation and with partial rebalancing of the relationship between fullness and empty space in the interior space of the first defensive wall belt.</p> <p>The first objective that the project had were the most immediate conservation needs: they wanted to protect and preserve the walls from aggravation of the natural process of degradation, instability and collapse, which eroded other fundamental signs or the constructive history of the castle.</p> <p>It was therefore necessary to preserve and consolidate the surviving structures in various ways, suited to the different situations.</p>

	<p>The roofing works to shelter parts exposed by the excavations, and not otherwise protected, also have the function of reporting that the castle is once again guarded, that is, it is being raised from abandonment in which it has long remained and of which, however, it bears the signs that are not intended to be removed, but only mitigated, as they may be dangerous for the safety of visitors.</p> <p>The set of data and even fragmentary finds that the conduction of archaeological excavation and removal of the layers of collapse and accumulation has brought allows you to offer the visitors the legacy, traces and readings of life that took place in the castle.</p> <p>These remains of direct testimony, along with their reconstructive interpretations based also on indirect sources - written and iconographic - enrich the meaning and charm of the place, relying on the allusive capacity and evocative reconstruction that also individual objects and fragments have if inserted in a context capable of amplifying the message.</p> <p>The project therefore poses the theme of keeping these elements visually and emotionally linked to the site where they were found, in whose life they participated and of which today they are witnesses.</p> <p>During the restoration works from 2003 to 2010, several archaeological campaigns were carried out, which brought to light over 7 thousand artifacts and classified over a hundred types of masonry.</p>
Conclusion	<p>The project of conservation and protection of the castle has been carried out in a scientifically correct manner, using appropriate techniques of survey and diagnostic analysis and using materials and techniques fully compatible with the pre-existence.</p>
References	<p>Francesco Doglioni, <i>Il progetto di restauro tra conservazione a rudere e fruizione. Il castello di San Michele ad Ossana</i>, Proceedings of the seminars in Archeology of Architecture Trento, 2002-2004</p>



Photo 84. Castle of San Michele in Ossana



Photo 85. Preliminary archaeological surveys. Section of ancient paving at the entrance to the first enclosure

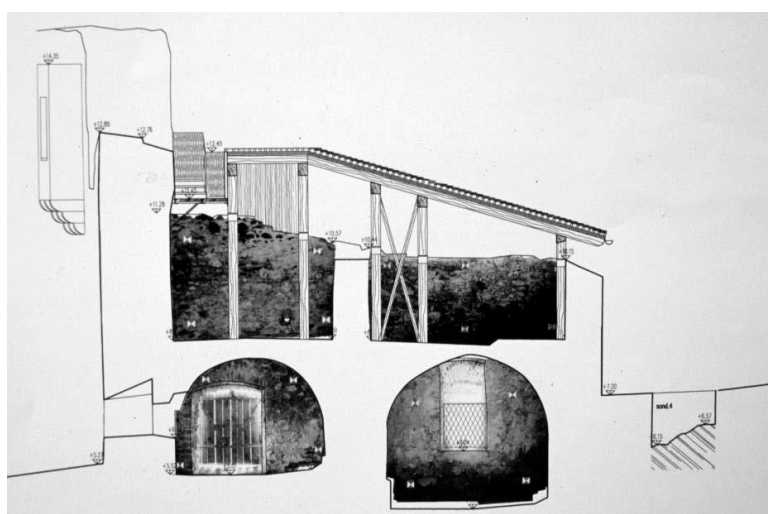

Photo 86. The final design: section of the castle with vaulted structures.

Name	Doria Castle in Dolceacqua (Italy)
Location	Via Tibaudo, 13 - Dolceacqua, Imperia. Liguria, Italy.
Heritage	<p>The Doria Castle was born as a fortified castrum in the 12th century, in the modern age it became the noble residence of the Doria family, which enlarged the original structure with the addition of the two square towers of the façade and the eastern bastion.</p> <p>The Castle is situated in a dominant position overlooking the village below, is in extreme point of advantage to control the the Nervia river valley.</p> <p>The “value” of the Castle is the close relationship with the place where it fits. Relationship so charming that it repeatedly brought Claude Monet to visit Dolceacqua and capture the bridge and the castle in a famous painting since 1884 housed in the Musée Marmottan Monet in Paris.</p>
Restoration	<p>After widespread interventions of restoration undertaken since the early 1990’s, the last restoration, carried out between 2012 and 2015, bears the signature of the Genoese studio LDA + SR (Luca Dolmetta Silvia Rizzo architects) and is aimed at the structural consolidation of the external walls, the re-institutionalization of the castle for museum purposes, the recovery of the main open spaces that surround the building, and the creation of a system of paths and walkways that allow visitors explore the ruins of the castle and discover several lookouts.</p> <p>There are many interventions carried out on the existing masonry, which is degraded and partly damaged, to eliminate any signs of instability, stone breakdown or erosion of the mortar joints. Biological attacks of efflorescence, deposits and superficial patinas are also widespread; frequent are the phenomena of deformation cracking and collapse that required a more important consolidation intervention, especially in the upper bastion and in the external perimeter of the castle.</p> <p>The project seeks to enhance the strategic position, enabling the visitors to go through the different stages of completion of the building, discover some enclosed spaces created in the few portions of the building which survived various bombings and ensuing fires over time, but especially follow a guided path towards the various land control points.</p> <p>The new Cor-Ten steel connections allow you to reach the top of the outer bastion and descend to the Savoy bastion (recovered as a terrace), to walk over the portico facing the courtyard of honor and to walk the “north sail” along a catwalk.</p> <p>The staircase, leaning against the wall, acts as a structural element to cope with the phenomena of bulging and disintegration of that part of fortification. The entrance to the castle has been renovated with the replacement of the existing railings, the placement of a new door and the closing of two windows; fixtures and wooden parapets also become in Cor-Ten steel, a material that aims to characterize the monument and the restoration work in a contemporary way. The interiors have been re-adapted to accommodate exhibition and multimedia rooms.</p>
Conclusion	<p>The restoration and strengthening of the extensively degraded masonry featured in significant form the intervention completed in 2015. The need for structural reinforcement or static improvement, though, was turned into an architectural project, including the use of iron parts that, depending of the requirement, have become paths, passages, elements of reconstruction of portions of walls partly missing or completely detached. Items always perceived as new parts, reversible and always side by side with the existing ones which they evidently match.</p>
References	http://www.premiorestauro.it/documents/69803/247180/Tavole+LDA.pdf/09c19f74-c8ba-45f8-8767-4d5376a41797



Photo 87. *Doria Castle in Dolceacqua*²⁶

²⁶ <http://www.premiorestauro.it/documents/69803/247180/Tavole+LDA.pdf/09c19f74-c8ba-45f8-8767-4d5376a41797>



Photo 88. Doria Castle in Dolceacqua. Details of intervention by LDA + SR²⁷



Photo 89. Doria Castle in Dolceacqua. Project panel by LDA + SR²⁸

27 <http://www.premiorestauro.it/documents/69803/247180/Tavole+LDA.pdf/09c19f74-c8ba-45f8-8767-4d5376a41797>
 28 <http://www.premiorestauro.it/documents/69803/247180/Tavole+LDA.pdf/09c19f74-c8ba-45f8-8767-4d5376a41797>

Rector's Palace in Zadar (Croatia)

Name	Rector's Palace
Location and Contact	Poljana Šime Budinića 23000 Zadar , Croatia info@knezeva.hr In the eastern part of the Zadar peninsula
Characteristics of the Monument	<p>The Rector's Palace in Zadar is originally from the 13th century and it has experienced many changes over the centuries regarding its use and the conservation. Historically, three restructured projects have taken place; in the 16th century, 19th century and in the 21st century.</p> <p>Recently (since 2017.), the Palace has been reconstructed with the support of EU funding and today it represents a modernly equipped cultural complex. It houses the museum space, its temporary exhibition halls and representative halls decorated and preserved in different historical styles. It also has a video gallery, concert and multimedia halls. In keeping with its natural and original beauty, the Rector's Palace is now a treasure of the city's modern and preserved monuments.</p>
History of the monument	<p>Historical sources documented the Rector's Palace dating back to the 13th century, and archaeological research works had revealed parts of the building from the Roman and Late Antiquity period as well as some wall structures showing Romanesque and Early Gothic layers. The Rector's Palace is mentioned for the first time in a document from 1288 under the name of „Municipal Palace“. Another records of the palace and its large hall date back to the documents from the 14th and 15th centuries where the meetings taking place in the Palace and the repairs of it were mentioned. In the documents from 1352, it is mentioned for the first time that the Council of Zadar Commune held their sessions in the hall of the Rector's Palace (<i>sala comitatis</i>). The Rector's Palace was then called the Great Palace of Zadar. The document from 1421 created by Chancellor Teodor de Prandin for the first time describes the location and appearance of the palace. Apart from its position and surroundings, the description mentions that the palace was built in stone and covered by hollow rounded tiles, and included taverns, storage rooms, a chancellery and 2 stables.</p> <p>The main room of the palace is the large hall, used as a courtroom in the 16th century, in the 18th century as a city theatre, in the 19th century as a hall for games and entertainment, and in the 20th century as a concert hall. As it changed functions, the palace also changed names and was therefore called municipal, court, governor's, government, and vicarious (vicar's) palace as well as the Chamber of Culture.</p> <p>In the 16th century, the palace was extensively renovated for the first time, as it is recorded in the historical documentation, it was repaired and rebuilt and therefore it received new stylistic features.</p> <p>At the beginning of the 19th century, in 1804, there was another reconstruction of the palace according to the designs of the classicist architect Francis Zavoro. Zavoro was given the task of redecorating the Rector's Palace and the adjacent Providur's Palace into an apartment for the Austrian governor of Dalmatia. This renovation completely changed the appearance of the northern facade and subjected it to new technical and aesthetic achievements in construction, in</p>

	<p>the systematic and symmetrical spirit of classicism. The renovation lasted from 1804 to 1807 and it represented the first accomplished classicist project in Zadar.</p> <p>Another major renovation took place in the late 19th century when the western facade and its surroundings were substantially altered. After World War II, the Rector's Palace enriched the cultural life of the City of Zadar for many years through its multiple functions as the public library, music and ballet school, concert hall, and it was the home of Radio Zadar, mixed choir of Petar Zoranić and girls choir of Juraj Baraković. During the Homeland War, in 1991 the Rector's Palace suffered great damage and destruction that visibly undermined the structural integrity of the building, enough for it to become unusable.</p>
<p>Protection and Restoration</p>	<p>The first demanding phase of the post-war reconstruction (static and building repairs) began in 1999. In 2006, the National Museum Zadar in cooperation with the City of Zadar made up the programme base for the Heritage Centre where all the exhibition spaces of the National Museum were supposed to be located. In 2011, with the help of the City of Zadar and Zadar Conservation Department, the National Museum launched a campaign for the temporary adaptation of several halls for exhibition purposes. An architectural installation was set up which looked like "cages"« that transformed spaces inside into suitable exhibition space. Exhibition pontoons were interconnected by wooden bridges and tunnels.</p> <p>In May 2011, a part of the renovated space of several halls in the Rector's Palace was opened and used for temporary exhibitions of the National Museum Zadar. Shortly after opening, the Rector's Palace became recognized as one of the most attractive city locations and has been the venue of exhibitions, special exhibitions for significant anniversaries, concerts, plays, an international film festival, diplomatic and city receptions.</p> <p>Project "Reconstruction and tourist valorisation of cultural and historical complex of the Rector's Palace" R.C.1.1.05-0117 was approved for funding from the Operational Programme "Regional competitiveness 2007-2013" in the Call for the development of business infrastructure. The project implementation started on 2 October 2014. The Project coordinator was the City of Zadar. Its partners were National Museum Zadar, Zadar Tourist Board, Zadar County Development Agency - ZADRA NOVA and the University of Zadar.</p> <p>This element includes both constructing the building and equipping it in order to ensure the existence of core infrastructural projects with the aim of fulfilling the purpose of this project. It is exactly this element that helps Rector's Palace have an adequate function by satisfying the need for a showroom, as well as music and multimedia hall all at once.</p> <p>The official opening was on 10 February 2017.</p>
<p>Conclusion</p>	<p>The project's aim was to create a recognized integrated cultural and tourist product of Zadar through the reconstruction and preservation of the historical monument. This meets long-term needs of the city, the county and cultural / touristic institutions by introducing the same culture in a modern, innovative and attractive way, which brings competitiveness of the new cultural and tourist product to a higher level. Correspondingly, it encourages entrepreneurship whose services represent persistence in the overall city offer.</p>

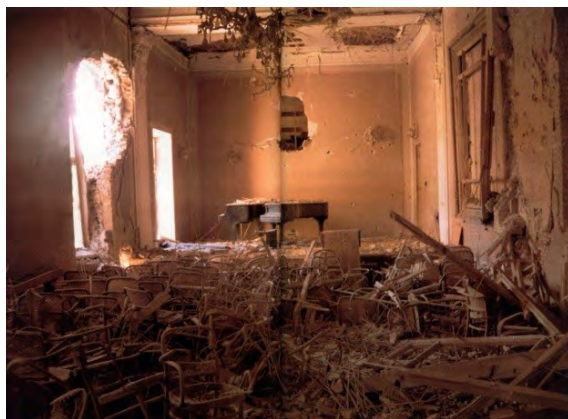

Picture 1 and 2. The demolition of the concert hall in the Homeland War and the refurbishment of the same Hall in the recent restoration of the Monument. (source: www.knezeva.hr)



Pictures 3 and 4. The Palace at the end of the 20th Century. (Source: Arif Ključanin 1991. *Slobodna Dalmacija*)



Picture 5. The Palace throughout its history. (source: www.knezeva.hr)

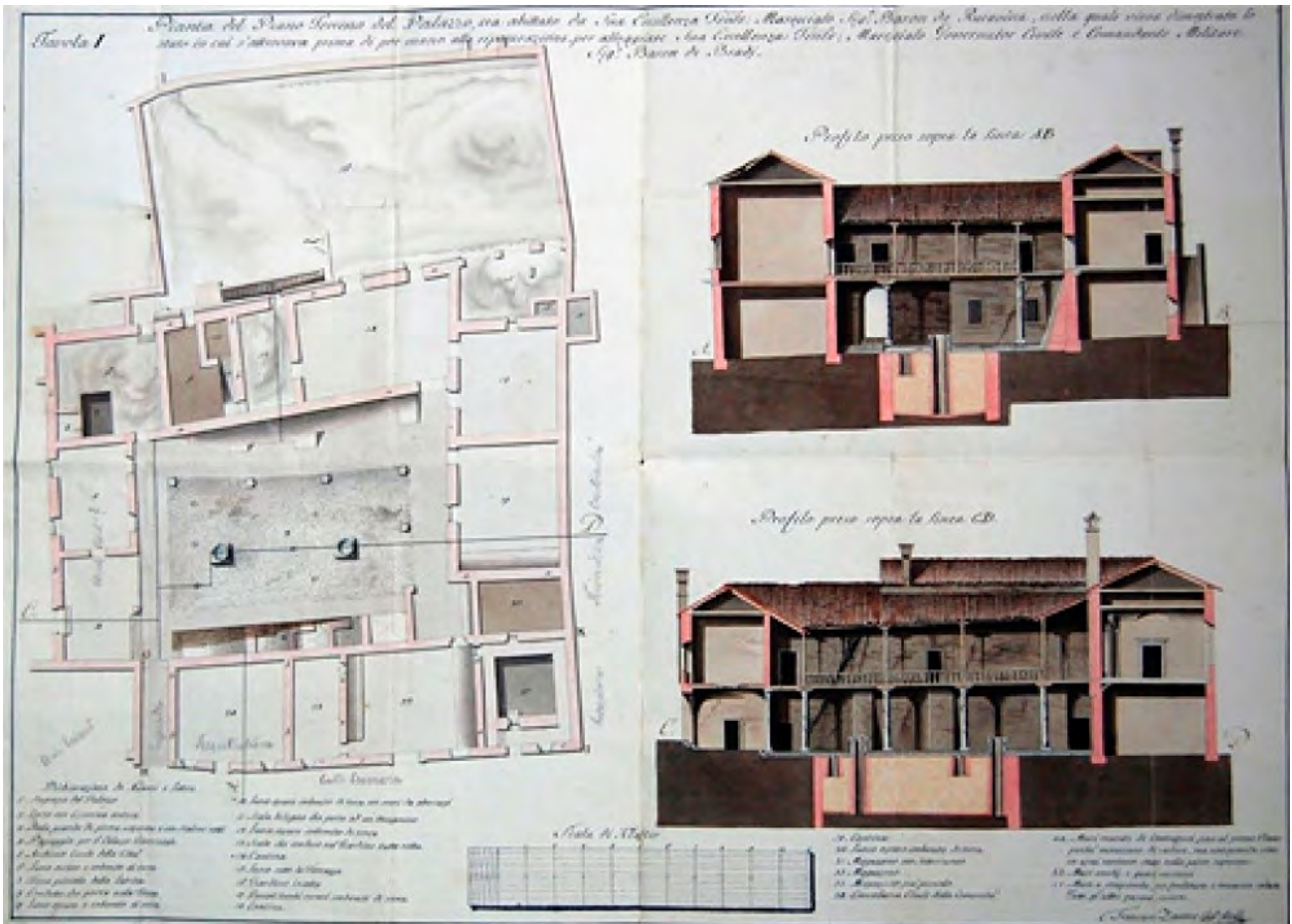

Picture 6. The Palace throughout its history. (source: www.knezeva.hr)



Picture 7. The recent and the latest restoration of the Palace. (source: Antena Zadar, archives).

The medieval fortress-tower (donjon) in Valpovo (Croatia)

Name	The medieval fortress-tower (donjon) in Valpovo
Location and Contact	<p>The Castle of Prandau-Normann 31 550 Valpovo, Croatia City Council of Valpovo, mail@valpovo.hr</p>
Characteristics of the Monument	<p>Built in the 14th century as a fortress tower (<i>donjon</i>) of the medieval city-castle of Valpovo, owned by the noble family of Morović (de Mároth), the tower remained intact during the great renewal of the castle in the Baroque époque, when the Valpovo estate was held by the Austrian family of Hilleprand de Prandau. Although the tower was greatly neglected, the original medieval structure and its interior, with stone windows, portals, staircases, vaults headstones and niches, is preserved.</p> <p>The last restoration of the monument ended in 1983, after which the tower was opened to the public as an <i>in situ</i> exhibit of the medieval military and civil architecture. Sadly, the restoration was done with inadequate materials and the reconstructions were overly idealized. Today, the construction and the statics of the tower are in poor state, the tower does not meet the modern standards of an exhibition space and its surroundings and it is closed for the public. [Pictures 1 and 2]</p>
History of the monument	<p>By the grants of Sigismund of Luxembourg in 1397, Ivan Morović acquired the large estate of Valpovo, in the center of which he began the construction of a castle/citadel or the fortified city of Valpovo, which would become the seat of the noble family of Morović (de Maroth), one of the most powerful Croato-Hungarian medieval noble dynasties. The medieval citadel of Valpovo had a shape of an irregular triangle: it's southern side was defined by a palas, and at the northern side stood a fortress tower of an irregular circle shape; on the east and the west side extended massive city fortifications, and in the center of the inner courtyard Morović family erected a gothic chapel. Construction works on the citadel of Valpovo neared end in mid-15th century., and Valpovo, a „Wasserburg“ type citadel, remains one of the biggest citadels in Croatia. [Picture 3]</p> <p>The medieval citadel was greatly rebuilt in the Baroque era, when, after the liberation of Slavonia from The Ottoman Empire, the estate was handed over to the Austrian noble family of Hilleprand of Prandau, in the first half of the 18th century. The renewal of the estate of Valpovo included also a reconstruction of the medieval citadel, which was transformed into the seat of the newly founded Baroque estate, with a great palace, built on the medieval palas, in the style of Baroque classicism (also, eastern and western fortifications were rebuilt as a side-wings of the castle). The only untouched medieval part of the citadel is the fortress-tower and the neighbouring portion of the former fortifications.</p> <p>That medieval-baroque complex remained in the hands of Prandau-Normann family until the end of the WW II, after which it was confiscated and declared as a national property. According to one document from 1964, the castle was used for various social and cultural purposes: Municipal Assembly and their offices, A Club for Antiquity Lovers, The School of Economy, The Museum Collection, The Communal Institution with warehouses, The Society of Pensioners, and as 6 flats (in later times, it was also the seat of The City Library, The Music School...).</p> <p>According to historic writings, the fortress tower was not restored until right after the World War II - a photograph of the tower from 1916 shows it's bad shape: missing a roof, the upper layers of the wall deteriorated and ruined due to disintegration of the bricks, while the remaining walls were covered with smaller trees and larger bushes. [Picture 5 and 6]</p>

	<p>From the conservator's report from 1955, we learn that the vegetation was pulled out and on the top of the fortress a large concrete slab was placed (that concrete slab was later called a terrace); also, we learn that the same concrete slab had already cracked, while the lower walls of the tower were surrounded by pigsties and chicken coops. To conclude, after the WW II begins a period of renewal of the fortress, which is nowadays interpreted as devastation.</p>
Protection and Restoration	<p>The first step in renovation of the tower was the above mentioned placing of the concrete slab - considering that there was no roof, the accumulation of storm water and it's freezing caused the cracking of the concrete slab and penetration of water into the lower parts of the fortress. That problem was meant to be solved by inserting a 2 m long discharge pipe just below the 'terrace', but that also resulted in more devastation, because the water poured down over the fortress walls which caused the weakening and the disintegration of the bricks.</p> <p>After its foundation in 1962, the Regional Institute for Heritage in Osijek launched a new phase of tower reconstruction, which included:</p> <ul style="list-style-type: none"> - 1966 - geomechanical research of the soil was conducted and it was confirmed that the soil presents no threat for the statics of the tower; also, the reconstruction of the crenelation of the tower was proposed. - 1967 - three rings of reinforced concrete were made in the three storeys of the tower, each ring holding one storey. In order to place the rings of reinforced concrete, walls had to be gouged and the rings were placed in those holes, which were later walled with new bricks; also, the ruptures or cracks in the walls were filled with concrete. [Pictures 6 and 7] - 1968 - on lower parts of the facades a grouting was made with cement mortar. - 1969 - erecting the crenelation began with placing another cement slab on top of the previous cracked one. - 1970 - the crenelation began to unravel, while the concrete-filled cracks began to widen; it was proposed to even out all the irregularities of the wall by concrete and cement. - 1972 - gouging another rings of reinforced concrete in the top storey of the tower, in order to proceed with the reconstruction of the crenelation. 1977 - proposal for further works: demolition of parts of outer walls in order to obtain a flat round surface, flattening of all the wall irregularities with cement mortar, grouting of walls with cement mortar. - 1983. - restoration of the fortress tower was completed. [Pictures 7 and 8] <p>By the end of the restauration, the tower was presented as of a pretty regular circular shape with open crenellation on its top. Today, it is possible to evaluate that restauration as an example of bad practice, from the technical as well as historical/stylistic point of view.</p>
Conclusion	<p>From the technical point of view, inserting the rings of reinforced concrete was not necessary at all, because, as it was explained by a certain prof. Ehrlich, the cracks or openings in the wall structure were formed just after the building of the tower, as a result of different foundations (meaning that the cracks were stable in the 20th c.). But, for the insertion of the rings the original walls were first gouged and then covered with concrete and cement mortar, which, being hydrophilic, caused weakening and disintegration of the surrounding medieval bricks. Also, filling the wall cracks with concrete, and grouting the walls with cement mortar caused the grinding and the dispersal of almost all medieval bricks of the tower, meaning that the statics of the tower was jeopardized.</p>

From the historical/stylistic point of view, the tower is presented as a medieval fortification with open crenelation, in spite of numerous historic graphical presentations of the tower, on which the tower is drawn as an oval one with a conical roof at its top (no crenelation). Also, the smoothing out of all the walls of the tower has resulted in losing its historical identity, because the tower had irregular walls. Likewise, the opening up of the doors in the ground floor has annulled the original entrance to the tower, which was placed in the first storey - that entrance was transformed into a window.

The described restoration can be judged as a devastation for two main reasons: it caused further deterioration of the medieval material, while also presenting an idealised type of a medieval tower which never existed in Valpovo. [Pictures 9 and 10]



Picture 1. The view of the fortress tower and the surrounding medieval fortifications (source: zhrmku.org.mk)



Picture 2. The view of the castle with fortress tower (source: darkoantolkovic.wordpress.com)

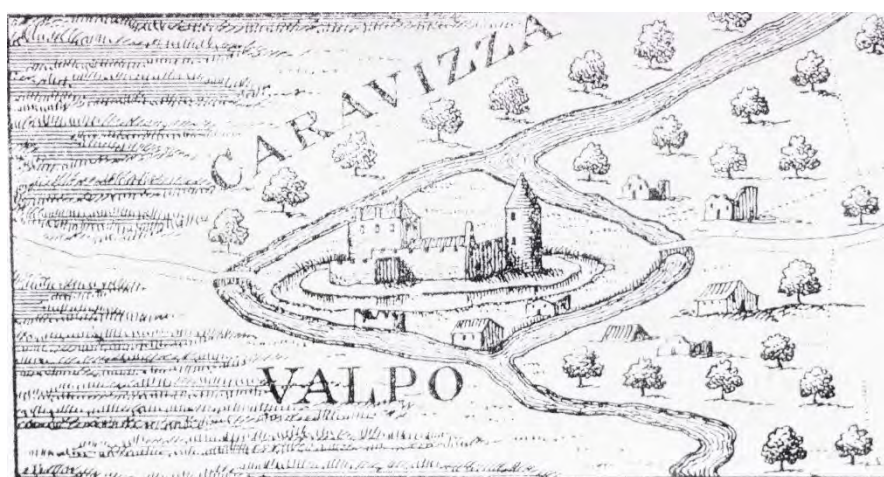

Picture 3. A drawing of Valpovo medieval city (source: Mažuran, Ive, Valpovo-Seven Centuries of Significant Past, 2004.)



Picture 4. The view of the chapel and the tower form the inner courtyard.



Pictures 5 and 6. Pictures present ruinous state of the tower. On the left is the photograph of the tower from 1916., taken by Gjuro Szabo, and on the right is a drawing of the Valpovo tower form the 19th century (Museum of the Valpovo County)

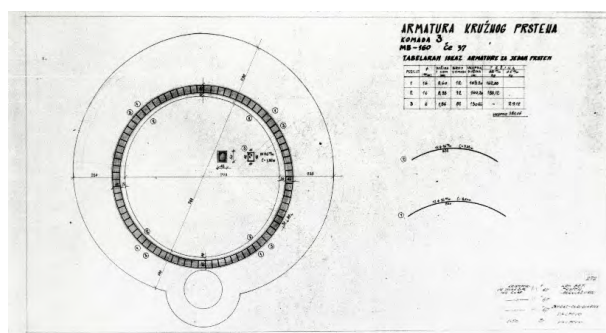
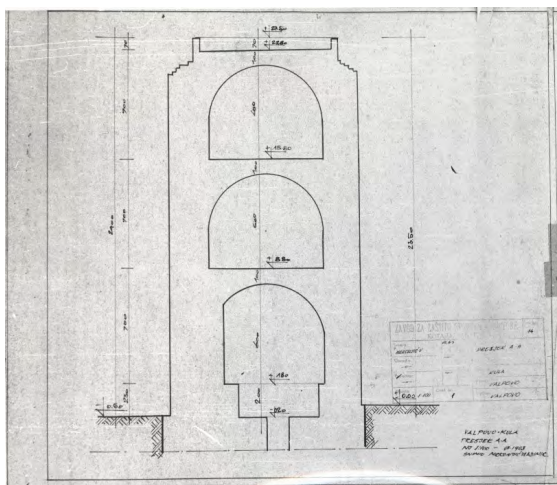

Pictures 7 and 8. Documentation from the renovation of the tower: cross-section of the tower and the design of the re-inforced concrete rings (source: Department for Heritage Osijek)



Picture 9. *The view of the tower in 1983, after its reconstruction. (source: Department for Heritage Osijek)*



Picture 10. *The present state of the tower: the “stains” on top of the walls indicate the restored parts of the tower as well as areas with increased amounts of moisture in the walls*

Claustra Alpium Iuliarum (CAI) is a late antique defence system that protected the Roman Empire against enemies penetrating into the centre of the Roman Empire. Archaeological remains of the system are accessible at intervals from Rijeka in Croatia to Posočja in Slovenia, and the position of the defensive walls indicates the purposeful use of natural features of the unrestricted landscape. Claustra represents an exceptional example of integrating architecture with the natural environment, and this is the idea that the visitors get. Archaeological remains are mostly found in areas covered with forests, often being part of the protected nature parks and under forestry regulations. Shareholders of this heritage are extremely scattered, and the not all the remains of the architecture properly conserved, presented and available, so it is necessary to increase their recognition with the aim of making this heritage a common destination of cultural and green tourism.

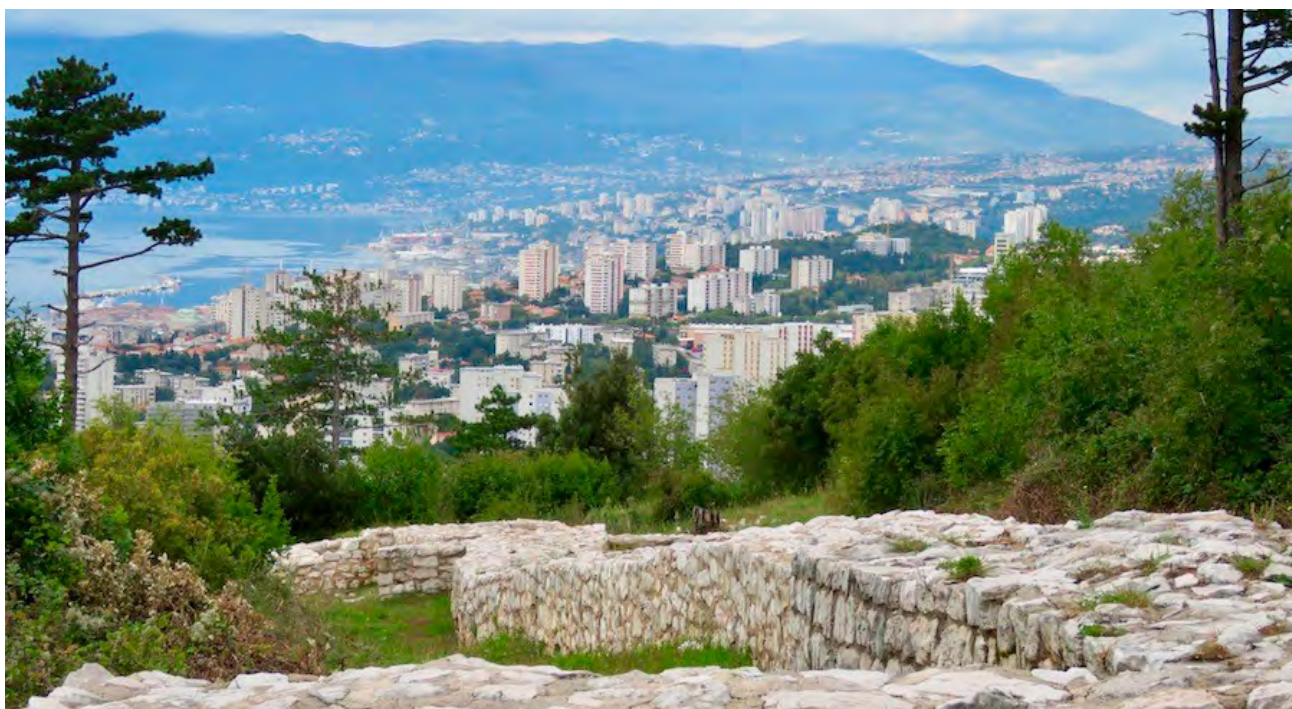

Photo 90 Part of the conserved roman defence wall, on the foothills of Rijeka

The project led by the Institute for the Protection of Cultural Heritage of Slovenia in cooperation with the Croatian Conservation Institute, the National Museum of Slovenia, the Ivan Michler Institute from Ljubljana, the Žmergo Association from Opatija and the Primorje-Gorski Kotar County, aimed at revitalizing the historical Claustra Alpium Iuliarum Roman lines in the territories of Croatia and Slovenia. It was co-financed from the Instrument for Pre-Accession Assistance (IPA) fund.

The aims of the project were:

- to draw up a management plan for the remains of the Claustra Alpium Iuliarum Roman defensive lines in the territories of Croatia and Slovenia,
- to raise awareness of the public and the targeted groups (youth, tourist economy, entrepreneurs and the local community), based on recognizing Claustra and its potential, about the development possibilities of the preservation and sustainable use of this heritage resource for local cohesion and economy, and
- to develop actual cooperation among cultural institutions of both countries, by exchanging good practices, with the application of advanced technologies of long-distance surveying and non-destructive reconnaissance methods and by coordinating conservation viewpoints.

Croatian Conservation Institute's project activities included documenting of the existing parts of Claustra (gathering historical cadastral plans and studying the toponymy of the Claustra terri-

tory in Croatia) and field reconnaissance in Croatia and in Slovenia (a mixed team of specialists from both countries), based on spatial data and through the use of LiDAR and aerial photography, archaeological excavations at some known sites, interpretation of results and the conservation and the analysis of movable archaeological finds. Croatian Conservation Institute's activities also comprised a comparison between the legislation and conservation viewpoints in the protection of cultural heritage of Slovenia and Croatia and a coordination of management plans, conservation plans, the methodology of recording and valuing heritage, the ways of preserving and presenting it, the cooperation in developing a documentary and a website, giving public lectures and preparing publications and exhibitions.

The project was followed-up by the archaeological excavation led by the Croatian Conservation Institute, where remains were unearthed of a principium of a military camp from the Late Antiquity, from where the defensive wall towards Italy was monitored, in addition to the archaeological excavations of the Claustra route in the territory of Primorje-Gorski Kotar County.

An indirect aim of the project was to prepare the documentation and the cooperation for the transnational application to include Claustra in the UNESCO World Heritage Site List.

After finishing the first project, the second one was established, called „Claustra+“. Its main goal was to focus on the active protection of the heritage, based on the sustainably developed tourism of the historical Roman fortification system. Again, the financial support was mainly gained through the foreign funds, namely EFRR - Interreg Slovenia Croatia. The project activities include preparation of guidelines for development and design of the promotion, design of cultural-tourist routes and related itineraries, systematic product promotion (including mobile application), and development and performance of a rich program for visitors (cross-border public events, experiential guidance). For the development of a complete product and a stable management of the cultural and touristic route, the bottom up approach will establish a cross-border consortium of CLAUSTRA that will unite all the important stakeholders and link local business entities. The second set of project activities is designed to increase the attractiveness of the CLAUSTRA destination. This will be achieved through active protection and enriched presentation of archaeological remains and the implementation of measures to increase physical and informational availability, including the establishment of didactic points.

The old town of Modruš (Croatia)

Modruš is an old fortified town situated on the old transport route linking Croatia's inland with the coast. It was a centre of an old and big county bearing the same name, which was owned by Frankopan princes. On the hill stood a separate fortress called Tržan, while the town of Modruš was encircled with town walls, and adorned with many churches and monasteries. For a while, the town was even a seat of the diocese.

The town reached the pinnacle of its development in the late 15th century, but was then thoroughly pillaged by the Turks and its population gradually declined. The fortress, situated on a steep hill, served as a part of the military frontier until the Turkish threat ceased, and was then also abandoned. Today only ruins of the fortress on top of the hill bear witness of the big and significant town, and only traces can now be seen of its numerous buildings. A small town is currently situated in this area. It is quite amazing that the ruins of the fortress and the town have not been archeologically investigated or protected, although the town holds a significant place in Croatia's history and in the formation of Croatia's culture and literary heritage.



Ruins of the Tržan castle in Modruš

Tržan was a medieval fortress on the steep hill above the fortified town of Modruš on the eastern slopes of the Great Chapel, once (from the 11th century on) administrative headquarters of the spacious Modruš County, and today it is only a ruin in the southern part of Karlovac County. The Modruš castrum was surrounded by defensive walls, within which the central part occupied the tower and residential buildings, the northern part was used for economic needs, and the southern part for trade. The border tower is one of the most famous medieval towers in Croatia. Even though it was a known and significant town in the 14th and 15th centuries, after it was taken over by the Border Protection Troops in the 16th century, it soon began to collapse, which was noted even in the reports and drawings of military engineers who visited the fort in the 17th and 18th century. There were attempts to repair the damaged facilities and even some financial resources were approved by the government, but there is no information about how much was actually invested in building repairs. After 1720 the fort was completely neglected, but the military crew remained in it until 1791, when the danger of Turkish aggression was completely eliminated. From that time on, Modruš was abandoned, and left to the passage of time, and all that remains of it today are the ruins of the walls and the tower.

When thoroughly explored and studied, Modruš could provide a wealth of information and material remnants to the knowledge of the lives of feudal people, citizens and church authorities

between the 12th and 16th centuries. Archaeological activities and research of this complex (fortresses and suburbs) could gather a group of experts for material culture of the Middle Ages. Conservation of part or the whole complex is possible. By studying Modruš, we would also discover more about the Frankopan family which is very important to the Croatian history. But, still, there is no planned and financed comprehensive project to start with the conservation and to go even further with the reuse of this monument.

Conservation and rehabilitation would include gathering documentation on Modruš, recording the situation on the ground, surveying the complex and surrounding area, drafting the project, archaeological excavation of the fortress and suburbs. The question of the continuity of settlements, in this area of the structure of medieval settlements, of the territorial organization of the old parishes and the feudal lords, would be studied.

A proposal for including the conservation project in the cultural development program of the Ministry of Croatia was made, and even some initial activities were undertaken, but nothing more. It was decided that the conservatory study should include: results and analysis of previous archaeological research; analysis of historical sources; analysis of historical cartographic contributions with the translation and analysis of the description of cartographic contributions; analysis of archival art resources; analysis of the structure of the current state in relation to the genealogy of the construction structure, based on the geodetic data of the complete coverage of the historic area of Modruš, classical documentation of the existing state and three-dimensional polygonal model of the Old Town of Modruš.

What was proposed was funding the photogrammetric shooting of the ruins, the performance of communication and the rehabilitation of the most endangered part. Since the money was allocated only for a part of the proposed program, it is all still more or less proposals and ideas written and not done.

At the state level, however, there is also no strong desire to renew and present our historical heritage, and as well as the local government who is not interested and does not see the possibilities for its own development and economical benefit. Until there is a proper plan for the future use, as well as a settled project of managing and visible outcomes provided for the local community, not much will be done, no matter how important this part of heritage is.



The Kost Castle seen from the south-west (photo Michal Panáček 2015)

Kost Castle is one of the best preserved mediaeval fortified seats in the Czech Republic. It was built by Peter von Wartenberg, a leading courtier of the King Charles IV in the second half of the 14th century. The upper part of the castle, situated on the peak of a sandstone rock, is equipped with parapet walks and battlements permitting more active defence of the site.

The ramparts consist of approximately 2.5 m thick walls, on top of which the massive merlons protect a spacious parapet walk used by defenders. The walkable area consists of large stone slabs laid in a gentle slope. Single merlons are topped by roofs of trapezoidal shape, all made of big sandstone blocks. The corner of the wall is protected by a small square turret. To build the walls a regular ashlar masonry technique of three leaf walls with a rubble infill was extensively used around the castle. The walls are not plastered; mortar in the joints recedes slightly into the wall. Among the unique remnants of the original equipment, there are gutters to hold folding shutters which would have been used to protect the openings between merlons.

Northern and north-eastern sections of the castle wall gallery have been preserved in an almost authentic state that corresponds to the late 14th century and has undergone no major reconstruction or even restoration.

Sandstones of different granulation, colour and quality come from local natural sources. The large variation, given due to the layers of sedimentation, helps to account for the typically multifarious and vivid look of the castle and is one of its distinctive properties. Despite the partial surface degradation, which of course corresponds to the length of exposure of the blocks to the weather for almost seven centuries, the stone used is still very firm and consistent. External surfaces are deformed by corrosion which has produced depressions or even deep caverns and are covered with deposits and crusts. Due to the degradation of the bonding mortar, the stones covering the top of the merlons have been loosened. The upper parts were significantly degraded and one gutter is completely missing. The walls, however, are solid.

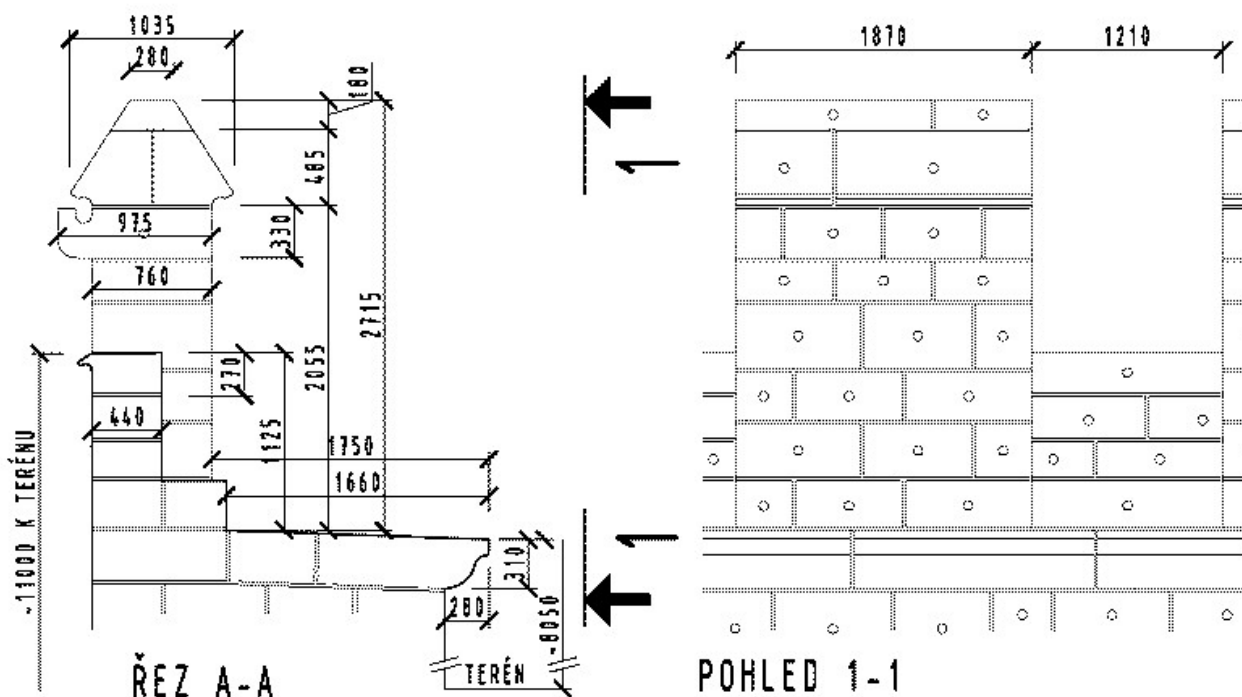

A section and front view of the parapet wall situated on the eastern side of the castle

In the past only routine maintenance and repair of grouting masonry was performed. The western half of the southern section of the wall was damaged in the past and actually repaired at the end of the 19th century. The fact that only limited repairs and alteration have been carried out demonstrates the quality and durability of the original workmanship which necessitates a maximum degree of protection and absolute caution in approaching regular maintenance and any restoration. These structures can be seen as not only as historical artifacts but as art, viewed as a kind of architectural sculpture. Any intervention to a building should be such as not to affect in any way the surviving original historical form and material.

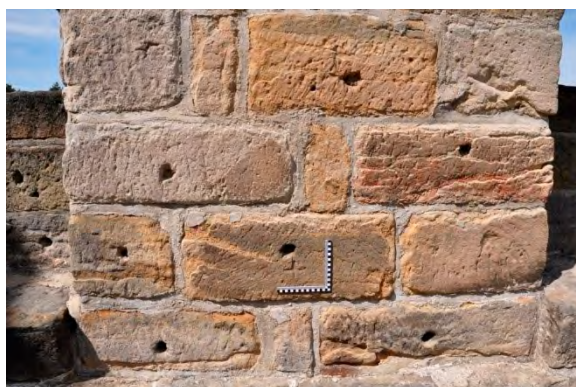

Various traces on the surface of the wall: signs of transportation, tool marks, stonemason's mark, traces of weathering and aging

About the method

The high degree of authentic preservation of the wall galleries and their significance required a highly responsible approach to recording and investigating when planning the restoration. Therefore a detailed photo documentation of the initial state was taken and also geodetic-processed photoplan of the facing surfaces to serve as a basis for all the related research and designs. Those that followed were:

1) A structural history research - mapping the historical context of the construction and subsequent amendments

A state-of-the-art report including the history of site and construction, analysis of archive sources, survey of its own construction characteristics, documenting of stonemason's marks, distinguishing the newer modifications, an architectural and art historian evaluation and the determination of its specific heritage value.

2) Historic traceology research - analysis of tool marks and traces

Detailed analysis of traces of tools used in stone processing, identification of historic instruments and technological steps, an ideal reconstruction of the technological process of craft production of blocks, guidelines for the preparation of new substitute stone blocks in compliance with the integrity of the original medieval structure.



The replicas of period tools used in the repair (photo Michal Panáček 2014).

3) Geological survey of possible material sources

Description of the historical rock material used in masonry, a determination of its composition, investigating the geological characteristics of the site, a survey of historic deposits in the vicinity and identification of possible future sources of stone for alternative rock material.

4) Pre-restoration survey and proposal of remedial measures

Description of damage, deterioration and other defects of stone and mortar in joints, material analyses of historic mortars, assessment of its state as a whole and its individual components, the long-term behaviour of structures in relation to the damage, remedial design and construction intervention; identification of damaged rock material necessary to be changed; limits and conceptual principles of recovery.

Implementation of this methodical procedure made it possible to obtain adequate historical, technological, technical and structural surveys and investigations, and subsequently propose an optimal procedure for the repair process of a particular historical structure using replicas of period tools and processing techniques.



One of the merlons on the battlements before and after the repair

References

- [1] Cihla, M. & Panáček, M.: Úvod do problematiky středověkých technologických postupů opravy stavebního kamene, *Forum Urbes Medii Aevi*, vol. 6, pp 4-25, 2011 (in Czech).
- [2] Bláha, Jiří: Historic traceology as a complex tool for rediscovery of lost construction skills and techniques. In: Brebbia, Carlos A., (ed.): *Structural Studies, Repairs and Maintenance of Heritage Architecture XIII*; Wessex Institute of Technology Transactions on The Built Environment 131/2013, WIT Press, Ashurst 2013, s. 3-13.
- [3] Bláha, J. - Chamra, S. - Panáček, M. - Rafl, T.: Repair of the ashlar masonry battlements of Kost Castle within the Lapidarius Project. In: *Science and Technologies in Geology, Exploration and Mining. 13th SGEM Conference Proceedings, volume II*, Sofia 2013, s. 325-332.
- [4] Bláha, J. - Panáček, M. - Chamra, S. - Kovářová, K. - Rafl, T.: Criteria for the selection and processing of a stone for replacements and repairs of ashlar masonry. In: LOURENÇO, Paulo - Haseltine, B. A. - Vasconcelos, G. (eds.): *9th International Masonry Conference*. Guimarães 2014, s. 1-9.



The Lipnice Castle as seen from the south (photo Jiří Bláha 2012)

The partially ruined castle in Lipnice nad Sázavou in Vysočina Region is one of the largest Czech castles, founded in the early 14th century by the powerful Lords of Lichtemburk. Throughout the history a number of influential personalities including Bohemian Kings Jan and Charles IV appeared here as owners. In the 16th century it was converted into an imposing noble residence by Trčka of Lípa and Thurn noble families. From 1636 the Lipnice castle was held by a Burgundy nobleman Matthias Vernier de Rougemont. In 1645 it was seized by Swedish troops, and then besieged and recaptured by the imperial army in 1646 after four weeks of fighting. Neither the castle nor the town fully recovered from the blow of the Thirty Years War. In September 1869 Lipnice was severely damaged by disastrous fire that devastated not only the whole castle but also most of the town. The burned ruin remained vacant until 1913, when the rescue and renovation works began. During the windstorm in 1916 the upper part of the Great Tower collapsed. The famous Czech writer Jaroslav Hašek used to conduct tours of the castle. He came here in 1921 and lived in Lipnice until his death in 1923. From 1924, the castle was managed by the Czechoslovak Tourist Club. The association secured the remaining walls and vaults with necessary stabilization works and opened the castle museum here. The rescue works went on until 1953, when the castle became state property.

In the 1970s and 1980s, an ambitious full scale reconstruction started with the intention to place the Jaroslav Hašek's Museum here, which has not been never fully completed. Recently the more feasible concept of use is focused to familiarizing visitors of the castle with its authentic constructions and details as well as with its exciting history. During the last decades, the conservation works have been supervised and guided by the National Heritage Institute; after the remodelling of some unsuitable interventions from the last century, the public accessible area is still expanding and the castle courtyard suits very well the organization of a wide range of cultural and educational events.



The Lipnice Castle as seen from the south after the fire in 1869

One of the biggest difficulties of alterations made in the second half of the 20th century was the lack of finance. The stabilisation works progressed very slowly and the whole concept grew obsolete before the entire reconstruction of the castle was completed. Moreover, the disadvantages of the technological processes selected at that time, based mainly on the use of reinforced concrete and cement grouting of stone masonry and vaults, began to manifest themselves in a very unpleasant way.



The Lipnice Castle as seen from the south in 1975

Complete reconstruction of the roofs was done only in the northern part of the premises (Samson's Tower, Thurn Palace, castle chapel). But even there still persisted problems related to excessive condensation of air moisture on impermeable concrete and cement surfaces. This situation improved significantly only after the replacement of the floors back to wooden boards and brick tiles and after removal of cement plasters and joints.

Controversial interventions

The inappropriateness of much of the conservation attempts made in the 1970s and 1980s can be best illustrated on Gothic Great Tower situated in the south-eastern part of Lipnice Castle. Its walls were severely damaged during the 19th century by a storm and subsequent fire. In December 1916 the weakened masonry of the tower had to resist another strong wind and so its essential part collapsed. The repair began only at the end of 1936. In the years 1968-1977 the perimeter walls of the tower were extensively strengthened with problematic concrete grouting. The asphalt insulation under the stone paving of the observation terraces lost its function after about two decades. The renovation of the insulation layers and removal of cement mortar from stone joints were carried out along with the structural stabilisation of the Great Tower in 2012. However, the problems persist as the rest of perimeter walls are still open for introducing of precipitation water. Therefore, the collections installed inside the tower had to be moved to a safer place.



High humidity in the interior of the Great Tower (photo Lucie Bláhová 2017)

To defend the designers of the former modifications, it should be noted that the observation terrace at the Great Tower was intended to be only temporary solution at its inception. Later, the tower was to be covered in the same way as opposite Samson's tower, which of course never happened.

A similarly complicated situation offers the adjacent Trčka of Lípa Palace, which is presented to the visitors of the castle in the form of an unroofed space enclosed by thick perimeter walls. The vaulted cellars situated below the palace also significantly suffer, apparently from draining water coming from the surface.

Experience with the long-lasting preservation of Lipnice Castle shows that at least for such a building with massive stone walls, the appropriate technical solutions have to be sought primarily among the traditionally used building materials.



The paved terrace on the Great Tower with the view to the Samson's Tower (photo DENÍK 2011)

References

www.hrad-lipnice.cz

Introduction

The Scaligeri domination in the city of Vicenza began in 1311, when the troops of Cangrande della Scala drove away the garrison of the Carraresi Padovani, and ends in 1387 with the arrival of Gian Galeazzo Visconti. Already in the previous era, settlements had developed outside the walls, especially in the early Middle Ages, towards the cities of Padua, less towards Verona. The new district towards Verona, called Portanova, was traced with orthogonal streets by the architect Giovanni da Ferrara.

Of notable interest is the Santa Croce Gate, which has two passages: for cars and pedestrian one. On the façade there were large grooves where the supporting beams of the two drawbridges were located. Santa Croce Gate is one of the ten city gates, provided with a tower. According to the sources (Conforto da Costoza, *Frammenti della Cronaca*), its construction began around 1381. Today, it is the most conspicuous and intact example of the city fortifications of Vicenza and also an existing trace of Scaligeri's building system, since Verona has lost most of its heritage during the Venetian domination.

Historical development

Originally, the tower of Santa Croce was completely covered by a type of plaster called “regalzier”, which was often used to cover defects resulting from the use of recycled materials. As evidence, we can point out the Fogolino's work entitled “L'Epifania” (1516 - *Image 1*), which shows a tower with a homogeneous wall face.



Image 1



Image 2

Regarding the roof, we can assume that in 1580 the tower was covered. In fact, within the “*Pianta Angelica*” (*Image 2*), which is dated exactly 1580, the tower was identified by a four-pitched roof.

In subsequent years, the small windows were enlarged, as the original use of bow and arrows was replaced with other weapons. Within these years, the original archery (window designed for archers) was completely removed and replaced with a larger window. In the context of the general restoration of the building this archery was completely reconstructed, in agreement with supervisory institutions, using examples from existing structures in the same geographical context and historical period. In particular, the construction technique is “*tholos*” (*Image 3*).

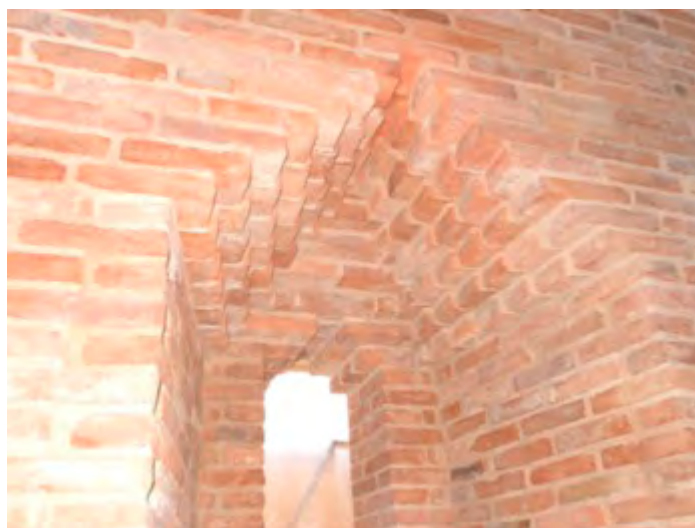

Image 1: “tholos” archery reconstructed

Stratigraphic, degradation and structural integrity analyses

Due to the importance of Santa Croce Gate to the city, the municipality decided to put in place a series of maintenance interventions, both as regards the structural field and for the restoration of the walls. During a first cognitive campaign, it emerged that the surface treatment of the walls really corresponded to the ancient “*regalzier*” technique, according to substantial traces, now unfortunately almost completely lost. Widespread in the Middle Ages, even in large European areas, this technique indicates the reproduction of a brick curtain on the façade of the monument, freshly painted on a thin layer of lime plaster.

Several interventions have taken place in this building: the first step was the securing of dangerous situations, such as crumbling walls, floors in need of repair, covering of the roof to be secured, debris removal. Afterwards, some improvement interventions were foreseen, such as installation of protective nets on windows, reconstruction of collapsed wall portions, arrangement of floors and stairs, structural assessments. Finally, exterior walls were restored and all the vegetation (ivy) that caused mechanical damage to the masonry was removed.

Stratigraphic analysis

The stratigraphic analysis helps to understand the main events that altered the building since its construction until today. In particular, we can observe the construction/application of the roof, which was not foreseen in the former shape of the building (see *Image 4*). We can see how subsequent interventions led to filling of the battlements in order to build the roof as we see it today.

In Table 1 below, some symbols related to stratigraphic analysis are explained:

Table 1

ID	Symbol	Explanation
A	≧	Stratigraphic relationship breaks / is broken, cuts / is cut applied to the perimeter of the surface that is cut (and therefore pre-existing).
B	⊂	Stratigraphic relationship “binds to ...” corresponding to the contemporaneity and stratigraphic consistency of two different surface units.



C		Stratigraphic report “leans, leans against, covers ...” symbol applied to the wall covering, indicates anteriority / posteriority ratio (the surface with the arrows is posterior).
D		Indicator of different planes between the surfaces of the walls.
E		True layer edge, intentionally configured edge.



Image 2: An extract of stratigraphic analysis

Thanks to Table 1, relationships between different planes, units or portions of the walls are clear and help us to understand main alterations suffered by the building. In particular, “C” and “E” symbols identify where the walls were filled.

Small *regalzier* traces are visible with the naked eye in some parts of the building. Obviously the general appearance of the building was completely different from today: there was no roof, and thanks to *regalzier* technique, the visual impact was a curtain of exposed brick. But due to the lack of the *regalzier*, we can nowadays observe the constructed system used by the Scaligeri for the tower and the gate.

Degradation analysis

Almost every intervention put in place for restoration and maintenance, regarded mainly the tower part of the building complex: in fact, it was the most critical portion. While the stratigraphic investigation was performed for the exterior walls, degradation has been inspected within the interior spaces of the tower. Moreover, at the time of the interior investigation, exterior walls had already been restored.

After the basic maintenance campaign, it was possible to comfortably access all levels of the tower, which were six stories, including the “attic” floor. During the years of neglect, vandalism was committed, which left heavy traces on the walls, but there were also traces of diverse uses performed in the tower, for example residential.



Image 3: Section with image showing straightening of internal walls







Image 5 represents the state of art when my investigation began. We can notice how different the windows between different stories are. This is a consequence of the several uses, during the centuries, of this tower. In particular, we can observe from the inside how the battlements of the last floor have been filled to allow the construction of the roof. As outlined before, most of the degradation came from vandalism, but there were also other causes (see *Image 6*).



Image 4: Degradation analysis through screening method

From the results of the inspections and the study of the images, as well as the analysis of solar exposure and materials, it was possible to identify seven main causes of degradation, summarized and described in Table 2.

Table 2

ID	Symbol	Explanation
A		<p>EXFOLIATION</p> <p>Degradation that manifests itself with detachment, often followed by fall, of one or more subparallel surface layers (sheets).</p> <p>Probably due to thermal fluctuations that cause the expansion and contraction of the material that comes off in flakes from the underlying parallel support; possible infiltrations of water that dissolve the parallel substrate.</p>
B		<p>CHROMATIC ALTERATION</p> <p>Alteration that manifests itself through the variation of one or more parameters that define the colour: tint, saturation and clarity. It can manifest itself with different morphologies depending on the conditions and can refer to large or localized areas.</p> <p>Possible deposits of dust and fumes due to the use of the tower as a dwelling (1970s-1980s); chemical attack by deposition of reactive dust with humidity.</p>
C		<p>ALVEOLISATION</p> <p>Degradation that manifests itself with the formation of cavities of variable size and shape. Alveoli are often interconnected and have non-uniform distribution. In the particular case in which the phenomenon develops in depth with a diverticula trend, carving alveolisation is defined.</p> <p>Probably due to freeze-thaw cycles in particularly sensitive portions. The tower in fact is not equipped with closing windows.</p>
D		<p>IMPROPER ELEMENTS</p> <p>Elements that are not part of the masonry as it was built at the time of construction of the building, but which are the result of the different use that is done over time.</p> <p>Remains of attempts at planned engineering in the period of adaptation of the tower for a dwelling (1970s-1980s) - telephone sockets, electric power cables.</p>
E		<p>EROSION OF MORTAR FILLINGS</p> <p>Mortar filling composing the walls have a different thickness (less) than it should have been originally. The causes can be many, but in this situation there must be considered infiltration of water from the roof (recently restored) and also the fact that there were no closing windows.</p>
F		<p>CRACKS</p> <p>Degradation that manifests itself by the formation of crevices in the material and which may imply the reciprocal displacement of the parts.</p> <p>Probably due to the presence of moisture in the layer. Alternating cycles of frost and thaw, the small amounts of water present increase in volume causing cracks in the exposed layer of plaster.</p>
G		<p>GRAFFITI</p> <p>Undesirable affixation of coloured paints on the surfaces.</p> <p>Intrusion of extraneous figures during the construction period that affected the tower in the years 2011-2012. Moreover, some walls show signs due to the actual construction site, for example to mark the tests that have been carried out on them.</p>

After having identified the causes of deterioration, the restoration of the walls was considered, assuming to remove the plaster and leave the exposed bricks. Installation of windows was also considered, since the main cause of internal degradations descended from the lack of proper closing windows.

In particular, four types of intervention were defined:

- A. Filling out cracks and missing wall fragments using hydraulic lime mixed with brick powder to assimilate the chromatism to the existing one. Application should be done through the use of spatula or needles, as necessary. Before application, walls must be dry and should not be damp at least for a week from the operation. Hydraulic lime could be mixed with different types of powder, as long as they are selected for purity and granulometry and without organic parts. The

application can be performed by hand or by mechanical machine, paying attention to temperature fluctuations. In the case of high temperatures, drying could take place excessively fast.

- B. Filling in mortar joints, for parts which are particularly critical and no more structurally reliable. The re-establishment must be performed in the same way in which it is intact, then set back 2-3 mm with respect to the section of the brick. This operation must be performed by hand using products that have no organic content and are characterized by the absence of reactivity towards sulphates. After application, the affected areas must be protected from frost and direct exposure to water for a period of at least 24-48 hours.
- C. Removal of the deteriorated and peeling plaster that presents heavy chromatic alterations. The operation will be carried out by hand with a 60 mm chisel and 1200 gr. brush in the most delicate points and with a compressor scaler in the less delicate points. The removal action of the plasters will be followed by a light sandblasting of the surfaces with a compressor, the granulometry of the aggregates will not be higher than 0.4-0.7 mm with a pressure of 3 atm. After sanding, a potassium methylsiliconate paint with water repellent and brick protection properties will be applied.
- D. After performing action "C" for all the internal walls, they must be protected through the use of a transparent water repellent coating. The product must be odorless and colorless and must not present risks for the operator or for the environment. The application must take place at temperatures between 5 and 40 ° C, should not be applied in situations with a risk of precipitation for the next 24 hours and the areas treated must be protected from frost.

The combination of the interventions described here above, also allows to avoid the formation of dust from the walls, that could be harmful for some uses to which the tower could be dedicated. In particular, the project included the insertion of a paper restoration laboratory, which required environments that were properly air-conditioned and free from elements that could damage the paper itself.

Structural integrity analysis

During the survey campaign, it emerged that some structural areas were no longer working properly. In particular, the building was equipped with a binding system embedded in the masonry consisting of wooden beams fixed to each other (Images 7, 8, 9, 10, 11). Even the roof presented structural problems as the wooden beams were very deteriorated due to moist and alternating cycles of frost and thaw.

After evaluations, it was decided to replace both the binding system embedded in the masonry and the structure of the roof, which is composed of two trusses. In particular, the roof trusses were replaced with ones identical to the existing ones.

The replacement of the wooden beams embedded in the masonry was a very hard work. In the first step, the walls have been pierced at the beams position, then the existing beams were unfastened and removed through the use of a tower crane and new beams were installed.

The roof has been completely removed and reconstructed in the same way as the previous one, maintaining the position and configuration of the beams and the same roof cover (tiles).



Image 5: *Position of the beams*

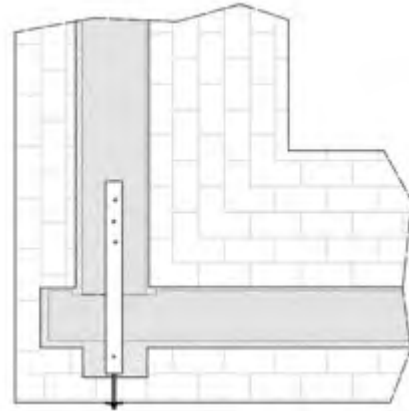

Image 6: *Bindings (plan)*

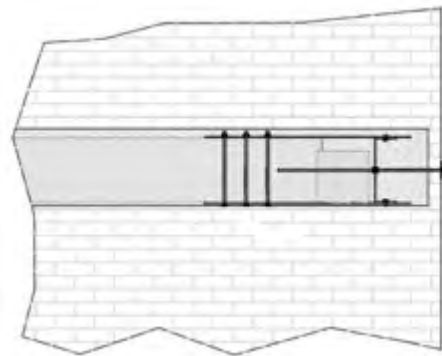

Image 7: *Bindings (front elevation)*

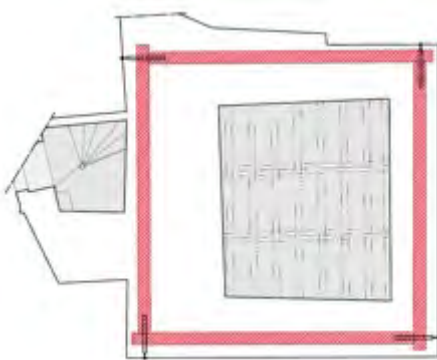

Image 8: *Position of the beams*

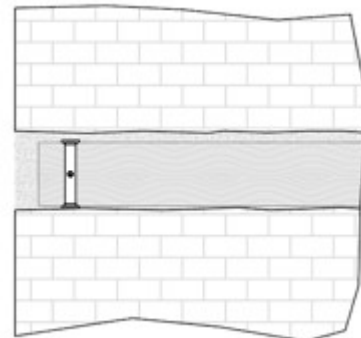

Image 9: *Bindings (plan)*

The images below describe the structural system of the roof, with construction details. The construction system is typical of trusses roof, using wooden beams.

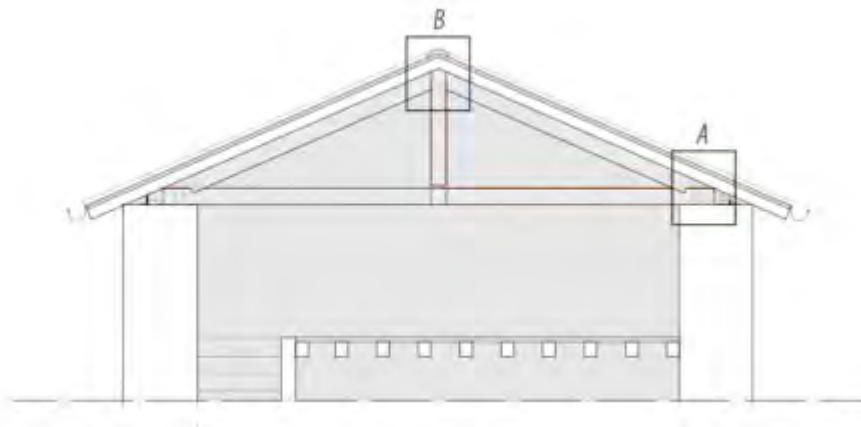

Image 10: *The fifth floor (front elevation)*

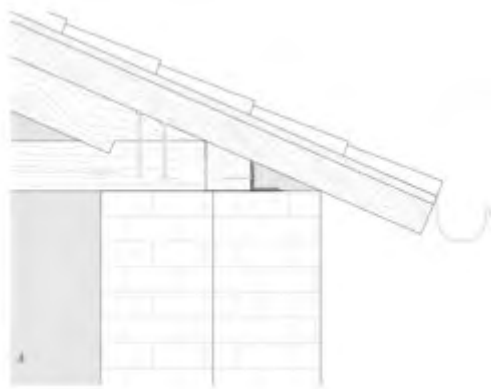

Image 11: *Beams (detail)*

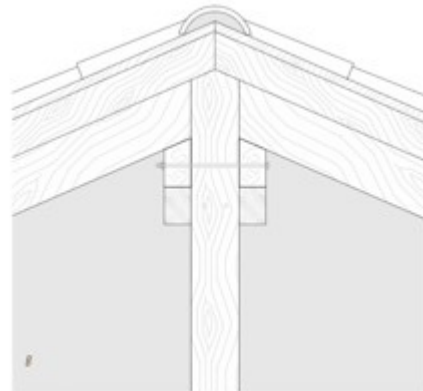

Image 12: *Beams (detail)*

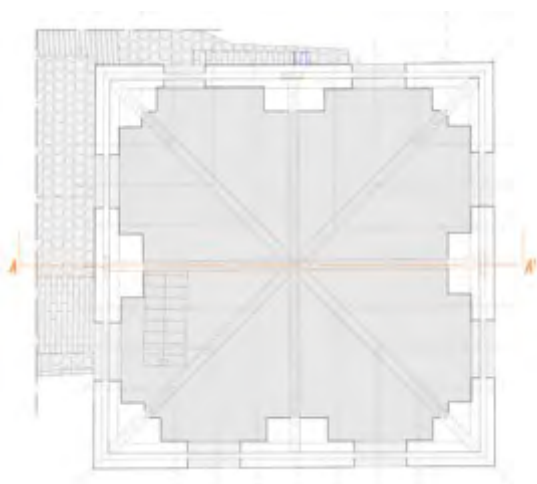

Image 13: *The fifth floor plan*

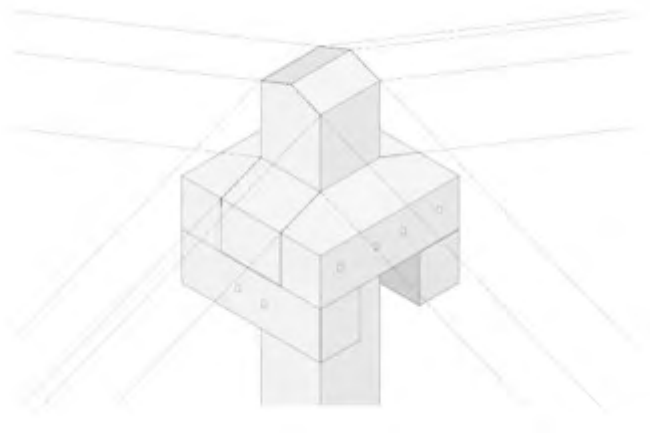

Image 14: *Trusses (detail)*

After these two interventions, the tower is nowadays secure, without possible harm and risk due to the deteriorated structures. However, the fifth floor, under the trusses, is not inhabitable due to the height of the trusses themselves, whose chains are 1.60 m from the floor. This height does not allow the comfortable use of the fifth floor. An alternative project proposal was drafted to make possible the use even on the fifth floor (*Images 17, 18, 19, 20*).

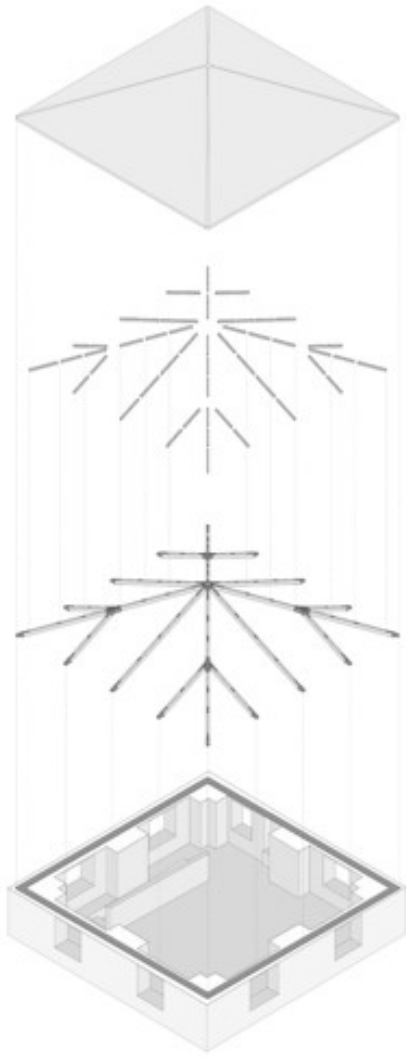

Image 15: Construction system

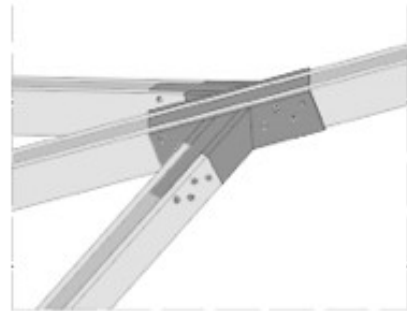
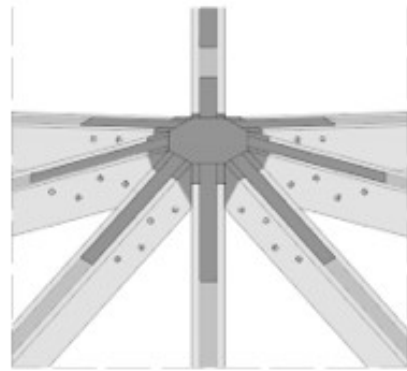

Image 16: Construction system

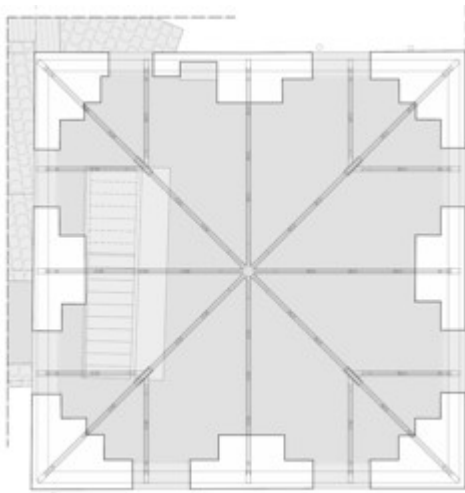

Image 17: The fifth floor plan

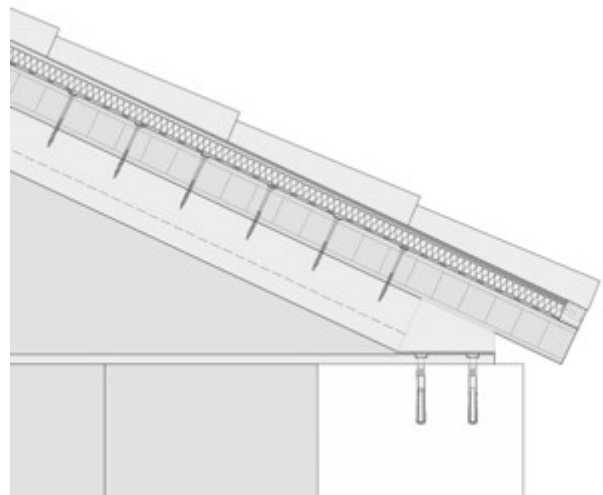

Image 18: Structural section (detail)

Conclusions

Santa Croce Tower and Gate are nowadays regularly treated and maintained, at least the portions restored, but there is no activity within these spaces. As already specified, several interventions took place, in different phases, but currently the building is not fitted with windows and doors, nor HVAC and electrical systems. Furthermore, other structural interventions could become necessary within the next years for all minor accretions around it.

The development of the tower allows to create semi-private environments which can be dedicated to different activities. The position, related to the city centre, and the high aesthetic value of this complex can be two strengths in the search for private investors for the management of this building, as the municipality does not have enough budget to improve management strategies nor heavy restoration programs.

These problems are very common for almost all the Italian heritage of that time. Structures must be often modified and remodelled to suit the needs of who decide to invest. Institutions are often a limitation rather than support, since they tend to conserve buildings exactly how they were 500 years ago. In this way, we find ourselves with buildings that only create costs and no profits, which require extraordinarily heavy maintenance and which are not as valued as they deserve to be. These buildings are dying, they are now only part of the city's background.

Images referenced.

- Image 1: Detail of *Epifania*, *Marcello Fogolino*, 1516 ca., *Civic Museum - Vicenza*
- Image 2: Detail of *Pianta Angelica*, *Giovanni Battista Pittoni*, 1579 ca., *Biblioteca Angelica - Rome*
- Image 3: "*Tholos*" Archery, photo by Arch. *Giulia Serblin*, 2012
- Images 4 - 20: Details from *Master's degree thesis* by Arch. *Giulia Serblin*, 2013

Introduction

The development of the city walls defence system of Mantua, surrounded by the waters of the river Mincio, is linked to an expansion that is believed to have occurred in three successive phases. The first circle of walls was erected in the eleventh century, following a generalized process of urban development of the majority of the European cities after an age of abandonment and decadence that has prevailed in the Early Middle Ages. The first development of the city walls was commenced following the path of the old Roman route, enclosing the north-eastern area of the modern city, between Piazza Sordello, Lake Mezzo and Lake Inferiore (later largely occupied by the ducal residence complex). Starting from 1190, the development of the second belt of defence system took place, in parallel with the intervention of the engineer Alberto Pitentino from Bergamo, aimed to set the regulation of the waters of the Mincio. Mantua witnessed a progressive development and a considerable population increase that led to enlargement of the urban core, which thus incorporated the suburb, located south, up to the artificial canal called Rio. The walls of the first circle were gradually losing their role and function and over time they were partly destroyed and partly incorporated into buildings that were placed on both sides. The second belt of walls therefore within the expansion to the south-west of the city extended beyond of the limits of the fossatum bovim (currently via Accademia); the new urban boundary was fixed by the Rio artificial canal, presumably reinforced along its entire length by non-permanent wall fortifications, including the insula cornu (later incorporated into the San Leonardo district). On the Rio there were four doors: Porta Leona (or Leone) on the axis of the current Corso Umberto I, Porta del Monticello (or Monticelli) on the axis of the current Via Roma, Porta dell'Ospedale on the axis of the current via Pomponazzo, and Porta Nuova on the axis of the current Via Fratelli Bandiera. The access to the new urban area, which extended to the north-west to Piazza Don Leoni, to the west as far as Viale Piave, to the south to Viale Risorgimento and to the east to the edge of the lake, took place through bridges. The suburb was defended by a moat (redevallo), a belt of water that surrounded the western and southern fronts, separating it from the islands of Te and Migliaretto. Next to the redevallo an embankment was erected (or terraglio), subsequently consolidated with walls. There were three access gates to the suburbs: Porta dei Folli, Porta dell'Aquadrucchio and Porta di San Marco.



The third belt phase of development was erection of the crenellated walls of the third circle, sporadically interspersed with towers and bulwarks, which surrounded the whole town that occupied the entire island area, excluding the two southern areas of Te and Migliaretto. To the north, in the stretch of walls between the dam-bridge of the Mills and the bridge of San Giorgio, a gate defended by a crenellated tower allowed access to the Ancona di Sant'Agnese. To the south of the castle of San Giorgio, in line with the bridge of the same name, there was Porta San Giorgio, also known as the Volto Oscuro, later incorporated into the Corte Nuova of Palazzo Ducale. Beyond this door there were Torre Nuova and three other crenellated towers belonging to the next section of walls, towards Porto Catena or San Nicolò. To the south the crenellated walls were inter-

rupted by Porta Pusterla and Porta Cerese, which led to the long bank that crossed the low lands of Migliaretto. On the south-western corner, where the walls bent roughly at the current Piazzale Gramsci and Via Fancelli, a closed tower stood, while a second shielded tower stood near the two triangular towers of Porta Pradella (formerly of the Aquadruccio). Proceeding along the perimeter there was then the turreted access to the Portazzolo di San Francesco, where still today a portion of the defensive wall survives with archer loopholes (balistraria).

At the beginning of the fifteenth century, Francesco I Gonzaga, along with hydraulic and defensive interventions that affected the surrounding countryside areas, after having already announced the division of the new districts in 1397, decreed the definitive expansion of the city, including officially also the whole area of the suburb, located south of the Rio (excluding the two southern areas of Te and Migliaretto), organizing the city to the best for any need for defense. The urban organism thus occupied the entire insular area with the consequent definitive configuration of the limits of the third circle of walls, effectively completed during the 16th century.

Background of the intervention

The goal of the intervention consisting in creating a wide open space green area, demolishing buildings to enhance the historical evidence that emerged after the archaeological excavation campaign in a „hinge” area between the urban redevelopment of the Piazzale Mondadori presented by the company Forum Mondadori and the Nuvolari park. This area is located on the border between the historic city and the new urban expansion, a border once marked by the city walls and Lake Paiolo towards the countryside. With the demolition of Porta Pradella this „sign” has been lost; nowadays the archaeological survey carried out by the Archaeological Superintendence has brought to light some architectural evidence of this past, such as the foundations of residential buildings, the most recent structures serving the former tramway station, the remains of the city walls and the patrolling walk, whose recovery and enhancement represent the rediscovered memory of a historical sign in the urban fabric of the contemporary city.



The urban walls recover their historical function of the connecting path with the restoration of the walkway. The location of a pedestrian walkway between the historic wall and the later retaining wall of the embankment represents the will to recover in this piece of wall a newfound relationship with the history of the city. In order to recover the image of continuity of the wall, now preserved in a minimal part, it is proposed to include pieces of brickwork in integration (of the ancient walls) that maintain limited heights and have a link to the historic walls. The walkway is made both along the part of the parapet and paving in perforated Cor-Ten steel sheets and is structured with a steel frame that rests on the floor of gravel laying above the embankment constituting the walkway.

Looking at the external profile of the walls, the walkway remains covered from sight in correspondence with the historical section, and then emerges in the integrated section of the base part of the brickwork. The intention is to give a figurative continuity to the walls, with an insertion of the cor-ten steel walkway which, due to its particular treatment, allows a coherent chromatic and volumetric integration with the historical masonry. This intervention, respecting the walls, is reversible, as the walkway could be removed without altering the historical system.

If the walls represented the „limit” imposed on the city for its development, the tramway marked, at the end of the nineteenth century, the will to exceed it with the construction of the bridge. The area between the four pylons will be bounded outwards by a cor-ten steel blade, and a layer of pebbles will be placed inside, in order to allow an adequate drainage of the ground. In this way, the „sign” of the moat that delimited the wall of the city walls will be visible.

The restoration work on the walls will be preceded by a series of diagnostic investigations on the materials and their conservation and by cleaning the surfaces.

The recovery project has also focused attention on the environmental theme of the area and on the study of routes and accesses that allow visitors to see and experience the archaeological space. There is in fact the possibility to reach the bottom of the excavation site through a path that gently follows the slope of the embankment, so as to allow you to walk on the grassy floor and admire the pylons of the former tramway and the profile of the city walls. The escarpment is connected with gradual and soft level curves to the excavation level, characterized by precise insertions of trees and hedges to allow simple management of the green areas.

The intervention as a whole represents for Mantua the opportunity to highlight how it is possible, in a major architectural intervention, to reconcile the preservation of the historical memory of the city with the necessary process of urban redevelopment and therefore of modernization of the city itself.

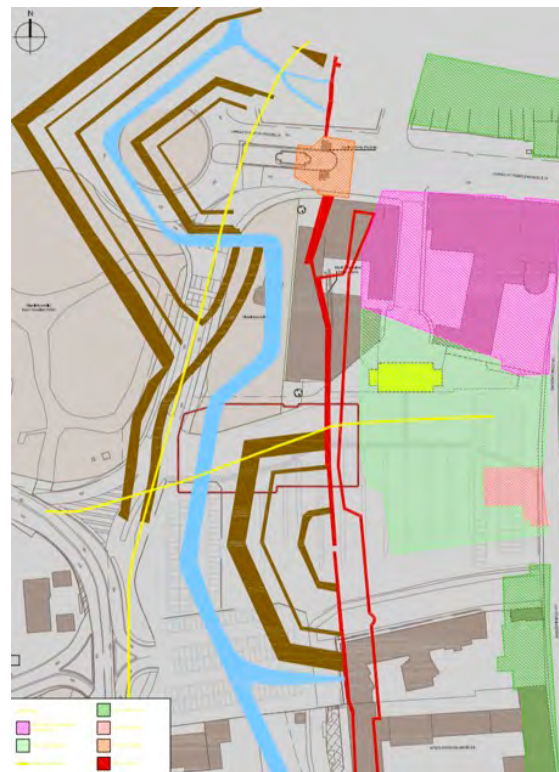

Structural archaeological analysis

A specific structural analysis of the archaeological analysis can be performed at three levels:

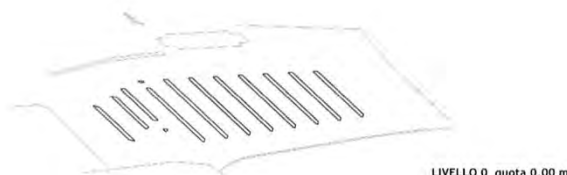

Level 0 (0.00 m)

The vast area of about 17,000 square meters, nowadays called Piazzale Mondadori and partly used as a suburban bus station and partly as a public parking lot, is completely unedified with the sole exception of the building of the ticket office built in 1888 for the use of the tram public transportation.

For more than a century, the area, straddling the line of the city walls, about halfway between this and Via della Conciliazione, the other half between the walls and the line of the ring roads, appears a sort of breakup of the usual compactness of the urban fabric and its margins.

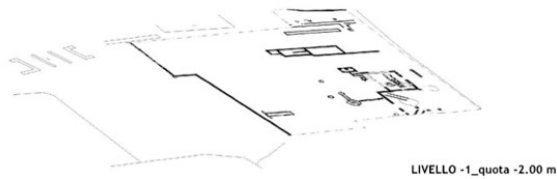

Level 2 (-2.00 m)

From the historical-archival research it emerges how in the last decades of the 1800s, the area object of the investigations is destined as a service area to the Mantua-Asola and Mantua-Viadana tramway built in those years. From the reading of the cadastral plan of 1881 a series of buildings and facilities appear functional to the new intended use. These constructions are reflected in numerous structures that emerged during the investigations, such as the goods storage warehouse, the water supplier for the machines, a machine and laboratory workshop, the tramway pylons.

The excavation area is crossed from north to south by a rectilinear wall structure (Renaissance walls), linked to a stretch of wall placed orthogonal to a more recent construction.



Level 3 (-3.00 m)

At a lower level of the excavation, structural remains of possible houses with cellars have been identified, subsequently demolished for the construction of the series of large and imposing buildings related to the new tramway.

The walls of these houses are made up of regular courses of broken bricks bound with not very durable grayish mortar.

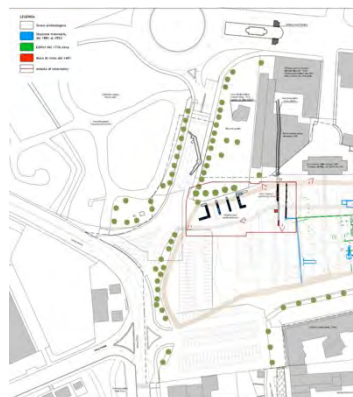

Restoration interventions of the walls

Arch. Florenzo Meneghelli.

All the process is divided into several phases:

1) Preliminary Investigations (Assessment of the construction, structural and material characteristics).

Before starting any conservation or non-conservation procedure of the historical artefacts, a series of preventive diagnostic investigations was carried out, aimed at the systematic and scientific acquisition of data concerning the real nature of the material and its conservation status. All the activities were performed according to the indications of the Conservation Superintendency.

2) Dry Cleaning of the walls

This type of cleaning was carried out on perfectly dry and non-friable surfaces, it was used to remove relatively coherent surface deposits adhering to the masonry surface, by using special sponges. The use of these sponges allowed to remove, in addition to the normal deposits of dust, a type of persistent dirt and substances which penetrated too deeply. The spongy mass is free from any type of harmful substance, has a neutral pH and contains saktis (a kind of lincosine), synthetic latex, mineral oil, vulcanized chemicals and chemically bound gelling agents.

3) Remotion of Macroflora

Macroflora includes all the macroscopically visible organisms (mosses, lichens, superior vegetation or herbaceous, shrubby and arboreal vegetation, etc.) whose development, on the masonry surfaces, is favored by the presence of damage to the walls such as crevasses, cavities, interstices, etc. , inside which it is possible to accumulate humus (formed by deposits composed of atmospheric particles and dead organisms), on which the spore deposits carried by the wind facilitate the reproduction of mosses and lichens; lichens create covering, fracturing, decohesion and corrosion phenomena; mosses cover the surface and enter in-depth, performing mechanical disintegration. The appearance of moss and lichens implies the presence of a high level of humidity and further increases its persistence, facilitating the accumulation and stagnation of water.



4) Restoration of joints

Execution of restoring of the moderately degraded joints, consisting in a thorough preliminary washing of the surfaces with water accompanied by light cleaning. The mortars to be used in the formation of the new joints consisted of a mixture of aerial lime, hydraulic lime with a low content of salts, river sands, with the addition of any colored earth, in order to obtain a grain and color similar to the existing mortars. For the deeper fissures, a low-salt hydraulic lime mortar and thicker river sand was firstly used.



5) Molding of the walls by partial replacement of the material (“scuci e cuci”/ un-sew and sew method)

The operation of un-sew and sew consisted in the repairing the walls through the partial substitution of the material; particularly the degraded walls, that were at the point of being irrecoverable and unable to perform the static or mechanical function, have been restored with „new” materials compatible in nature and size. The intervention was limited to just the wall

covering or extended throughout its thickness. The choice of the compensation material was done with extreme care, the new elements had to meet different needs and requirements: historical (if the intervention was operated on monumental structures), aesthetic, and above all technical ones; it had to be compatible with the pre-existing size (so as to avoid discontinuity of the wall and the onset of disconnection between the old and new) and the nature (a diversity of compactness could, for example, imply a different degree of absorption with consequent onset of spots). Where circumstances have permitted, it was convenient to use material recovered from the same site, carefully selecting it to avoid reusing damaged and / or degraded elements.

6) Reconstruction of wall's segments

Full masonry was supplied and installed, in solid sand with soft mix sandblasted on the surface for the reconstruction of the demolished and/or dismantled masonry. The material was produced using a soft-kneading (non-extruded) production technology, by manual molding in special „old-fashioned” formworks. The masonry was rebuilt in a similar way to the pre-existing one, in thickness and weaving, with natural hydraulic lime mortar with a low content of soluble salts, according to the procedures envisaged by the designer, in order to obtain a new seamless texture and the characteristics of strength and stiffness matching the the surrounding one. The new masonry was laid after careful cleaning, dust removal and wetting of the existing parts in contact, on which the reconstructed part was inserted. The bricks were burnt in a natural gas-fired kiln and had suitable chemical-physical characteristics for use in masonry and corresponding acceptance criteria established by the UNI EN 771-1 Standard, Category I, and was also accompanied by a relevant certificate of proof guaranteed by certification body external to the manufacturer. Also included are the charges for sealing and brushing the masonry, if necessary, to be carried out according to the procedures established by the Designer, and the preliminary construction of sections of masonry for the approval of the designer.



7) Inspection of the wall's upper surface

Execution of inspection of the upper surface of the top of the wall, in fairly conservative conditions, that consisted of the preliminary removal of the grasses, seedlings, residuals of dead vegetation, powdery or detached mortars, that was carried out manually with the use of small mechanical means. After a careful washing of the surfaces with water accompanied by light scraping with soft brushes, the possible integration of the missing stones was performed with recovered slabs available on site or provided by the company through research at local quarries, in order to reconstitute the drainage of water, which was followed by the restoration of mortar joints. The mortars used in the reconstruction consisted of a mixture of aerial lime, hydraulic lime with a low content of salts, river sands, with the addition of any colored earth, in order to obtain a grain and a similar color to the existing mortars. The final layer of styling mortar was made in satin with particular care, forming slight slopes towards the outside so that there are no stagnant water on top of the wall itself.



8) Foundation excavations

A partial excavation with obligatory section on ground of any nature and consistency and for any depth was carried out, including the necessary routing, backfilling at the end of the work and the removal to a landfill of the waste material or its arrangement within the building site, including leveling at the levels required by the management of works. The volumes deriving from the planimetric area obtained from the actual geometrical measurements indicated in the executive drawing for the actual height of the excavation were calculated without compensation for embankments or gouges. The reinforcement of the walls is included for depths greater than 1.50 m and any other burden Excavations with a forced section.

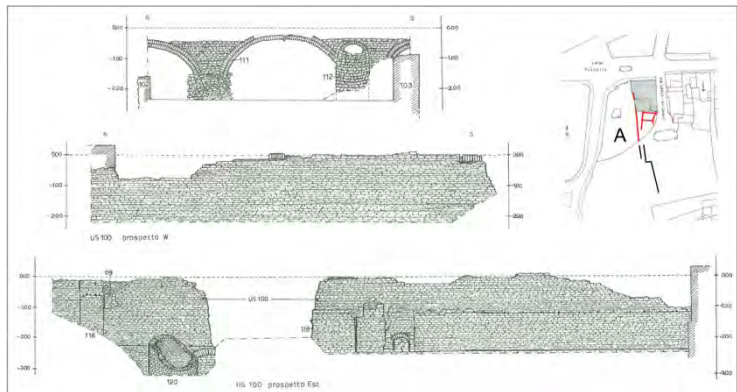

9) Inspection excavation and recognition

These operations were carried out only and exclusively upon explicit request and supervision of the management of the works., following the indications and the executive procedures expressed by it and / or by the technical staff in charge. The debris, the newly accumulated humus were always removed by hand with the utmost care, after inspections in order to determine the level of the original underlying floors (and their possible floorings) in order to avoid damage and breakage to materials that compose them. Unless otherwise specified by the management of the works, the removal of the materials were carried out by hand, without the aid of mechanical means. In any case, the use of mechanical means were subject to the presence of any findings in situ and, therefore, to the preventive investigation. If the materials coming from the excavations were used in a delayed time (e.g. for filling), they were deposited in the building site, in a place where they did not cause obstacles or damage.

10) Concrete conglomerate of existing walls and for foundation

Concrete conglomerate for sub-construction of the existing walls and for foundation dosed at 3 quintals / cubic meters of cement „325”, carried out in successive sections (construction sites) with two sites of interval, including shoring, supply and laying of hardwood wedges subsequently constrained, sealing of the upper stretch after pouring by filling with anti-shrinkage mortar, excluding the excavation to be assessed separately, every other load included. Armor incidence 45 kg per cubic meter.

11) Consolidation through enlargement of the basement floor

The operating consolidation procedures did not in any way alter the stability of the building system that was consolidated; therefore, it was necessary to adopt all the necessary measures and precautions for the safety of the building in compliance with current legislation. After execution, the temporary structures; the areas of intervention were identified by dividing them „into construction sites”; subsequently the excavation started on one side of the masonry or on both sides in the presence of thick walls (> 150 cm) or on the specific indication of the management of the works. Excavations (deep, unless otherwise specified, up to the level of the foundation floor of the old foundation) were sized according to the needs, in any case strictly related to the execution of the type of work, so as to ensure a good implementation of the reinforcement of foundation. Any consolidation operation in reinforced concrete or masonry had to rest on a smoothing slab in the lean concrete of cement conglomerate R 32.5 (dosed 200-250 kg / m³), not reinforced, with a minimum thickness of 10-15 cm laid on a flat horizontal surface cleaned of debris and regularized with crushed stone with a minimum thickness of 15-20 cm. For foundation works that were carried out with reinforced concrete it was necessary to provide for the installation of the woodwork of formwork, which was of adequate strength, waterproof,

well anchored and contrasted (in order to resist the hydraulic pressure of the fluid mixture), and sealed (with glue materials or with the same mortar with a plastic consistency) to avoid grout losses. Moreover, the wooden formwork had to be saturated with water (especially in warm and dry climate) to avoid the subtraction, by absorption, of the liquid from the mixture; finally, before the casting, it was necessary to apply the disarming agent so as to facilitate the operation of detaching the formwork.

12) Supply and installation of wall's waterproofing against double layer

Supply and laying of masonry waterproofing, consisting of two layers of polymer bitumen waterproofing membrane of 4 mm thick, reinforced with non-woven fabric, the cloth applied with over 10 cm overlap, flame-welded. It was turned up and glued on the vertical walls at least 10 cm above the floor. Double layered masonry waterproofing.

13) Drainage, cavities, crawl spaces.

The intervention procedures refer to various technologies designed to deal with the presence of humidity; the operations relate mainly to foundations or walls in the ground as elements that are easily impregnated with water, in liquid phase, coming directly from the subsoil, by capillarity. The absorption can occur at the foot of the foundations and on the floorings in direct contact with the ground (lack of the first floor slab). The elimination of a substantial part of ground which has containment function for the part of the bottom wall, could trigger failures and cause cracking patterns. In the probability that this might occur during the works, it was essential to intervene in advance with the consolidation of the structures and, later, with the excavation of the trench.

Conclusion

The project is an extraordinary opportunity of revitalization of a significant historical area of the third belt of the city walls, combined with the creation of a green area within an area that formerly was a public transportation hub and a city park, enhancing a recreational area within the wider framework of cultural and environmental heritage itineraries of the city.

7. Bibliography

- [1] Alaimo R., L. Di Franco R., Giarrusso V., Briuccia G., Montana G., Plasters from the historical buildings of Palermo (Sicily): raw materials, causes and mechanisms of decay, in: Moropoulou A., F. Zezza, E. Kollias, I Papachristodoulou (Eds.), Proceedings of the IV International Symposium on the Conservation of Monuments in the Mediterranean Basin, Rhodes 6-11 May 1997, Technical Chamber of Greece, vol. 1, 1997, s. 53-64
- [2] Atzeni, C., Massidda L., and Sunna U., Magnesian limes: experimental contribution to interpreting historical data, *Science and Technology for Cultural Heritage*, 1996, 5, s.29-36.
- [3] Balliana Laura Falchia Eleonora, Marco Piovesan, Manuela Sgobbi, Elisabetta Zendri. Stucco Forte in Venice between the 16th and 17th centuries: the case study of Addolorata Chapel stuccoes in San Pantalon's Church *Procedia Chemistry*, vol.8, 2013, s. 92-99
- [4] Bar E., Fałdrowicz J., Dokumentowanie zabytków architektury metodami fotogrametrycznymi i skaningu laserowego, *Acta Scientifica Academiae Ostroviensis*, nr 34, 2010, s. 5-14,
- [5] Bartz W., Filar T., Mineralogical characterization of rendering mortars from decorative details of a baroque building in Koźuchów (SW Poland), *Materials Characterization*, vol. 1, 2010, s.105-115.
- [6] Bartz W., J. Rogóż, R. Rogal, A. Cupa, P. Szroeder, Characterization of historical lime plasters by combined non-destructive and destructive tests: The case of the sgraffito in Bożnów (SW Poland), *„Construction and Building Materials”*, vol. 30, 2012, s. 439-446;
- [7] Bartz W., T. Filar, Mineralogical characterization of rendering mortars from decorative details of a baroque building in Koźuchów (SW Poland), *„Materials Characterization”* vol. 61, 2010, s. 105-115.
- [8] Basiul E., W. Bartz, A. Cupa, Badania diagnostyczne w konserwacji i restauracji zabytków, [w:] *Problemy konserwacji i badań zabytków architektury*, prac. zbiorowa pod red. A. Kociałkowskiej, Studzinaka 2007, s.195-222.
- [9] Brencich A., Sterpi E., Compressive strength of solid clay brick masonry: calibration of experimental tests and theoretical issues, *Structural Analysis of Historical Constructions*, New Delhi 2006
- [10] Brochwicz Z., Badania składu mineralnego sztucznego kamienia w XIV-wiecznych rzeźbach i elementach architektonicznych na zamku w Malborku, *PP Pracownie konserwacji Zabytków, Ośrodek Informacji Konserwatorskiej*, Warszawa 1984, s.5-79.
- [11] Brochwicz Z., Badania wczesnośredniowiecznych zapraw budowlanych - integralną częścią badań archeologicznych, *„Materiały Zachodniopomorskie”*, t. 22, 1975, s.95-245.
- [12] Brochwicz Z., Charakterystyka siedemnastowiecznych narzutów wapiennych występujących w elementach dekoracyjnych na elewacji kamienicy „Pod Gwiazdą” w Toruniu, [w:] *AUNC Zabytkoznawstwo i Konserwatorstwo*, t. 5, 1974, s. 69-90.
- [13] Brochwicz Z., Identyfikacja skrobi i związków białkowych na przekrojach warstw malarskich i zapraw, [w:] *Materiały Zachodniopomorskie*, t. IV, 1960, s. 539-545.
- [14] Brochwicz Z., *Materiały wiążące w budownictwie starożytnym i wczesnośredniowiecznym*, *Materiały Zachodniopomorskie”*, t. XIX, 1974, s. 753-791.
- [15] Brochwicz Z., Monochromia z wypełniaczem ceramicznym na sklepieniu kaplicy zamkowej w Golubiu, [w:] *AUNC Zabytkoznawstwo i Konserwatorstwo*, z. 53, 1973, s. 91-104.
- [16] Brochwicz Z., Zaprawa wapienna jako tworzywo elementów architektonicznych na przykładzie służek w kaplicy zamkowej w Radzynie [w:] *AUNC Zabytkoznawstwo i Konserwatorstwo*, Z. 44, 1973, S.127-139.

- [17] Bruni S., Cariati F., Fermo P., Pozzi A., Toniolo L., Characterization of ancient magnesian mortars coming from northern Italy, *Termochimica Acta*, vol. 321, 1998, s. 161- 165.
- [18] Brusaporci S., The Representation of Architectural Heritage in the Digital Age, *Encyclopedia of Information Science and Technology, Information Resources Management*, USA, 2005,
- [19] Brykowska M., *Metody pomiarów i badań zabytków architektury*, Oficyna Wydawnicza Politechniki Warszawskiej, 2003.
- [20] Building Research Establishment. Control of lichens, moulds and similar growths. Garston, Watford: Building Research Establishment, 1992.
- [21] Cardell-Fernández, C. Navarrete-Aguilera, Pigment and plasterwork analyses of Nasrid polychromed place work stucco in the Alhambra (Granada, Spain), “*Studies in Conservation*”, vol. 51, 2006, s. 161-176.
- [22] Cavallo G., Derighetti L., Napoli S., The emigration of prealpine lake masters: a study of a 17th-century mantelpiece attributed to the Carlone family of Rovio (Ticino, Switzerland), “*Archaeometry*”, vol. 47, 2005, s. 425-439.
- [23] Centofanti M, Brusaporci S., Interpretative 3D digital models in architectural surveying of historical buildings, *Computational modelling of objects represented in images*. CRC Press, London, 2012
- [24] Ciach. T., Osler S., Badania nad wczesnośredniowiecznymi zaprawami występującymi w posadzkach zabytkowych reliktyw w Wiślicy, „*Ochrona Zabytków*”, nr 3, 1970, s. 197-209.
- [25] Donnelly J., *Ruins: the Conservation and Repair of Masonry Ruins*, Government Publications Sales Office, Dublin, 2010
- [26] Donnelly J., *Ruins: the Conservation and Repair of Masonry Ruins*, Government Publications Sales Office, Dublin, 2010
- [27] Drobiec Ł., Lokalizacja wad konstrukcji i stali zbrojeniowej - metody, Conference: XXI Ogólnopolska Konferencja Warsztat Pracy Projektanta Konstrukcji, 2006
- [28] Eklund J. A., Young M. E., Biological Growth on Masonry: Identification & Understanding. Inform. Information of historic building owners. Published by Historic Scotland, January 2013
- [29] Eklund J. A., Young M. E., Biological Growth on Masonry: Identification & Understanding. Inform. Information of historic building owners. Published by Historic Scotland, January 2013
- [30] Elsen J., Microscopy of historic mortars - a review, “*Cement and Concrete Research*”, vol. 6, issue 8, 2006, s. 1416-1424.
- [31] Fawcett R., Treatment of vegetation at monuments [w:] *The Conservation of Architectural Ancient Monuments in Scotland. Guidance on Principles*. Published by Historic Scotland. Longmore House. Salisbury Place. Edinburgh 2001, s. 44-47.
- [32] Fawcett R., Treatment of vegetation at monuments [w:] *The Conservation of Architectural Ancient Monuments in Scotland. Guidance on Principles*. Published by Historic Scotland. Longmore House. Salisbury Place. Edinburgh 2001, s. 44-47.
- [33] Ferraby S., The ecology of ruin sites [w:] *Conservation of Ruins*, ed. John Ashurst, Elsevier Science & Technology, 2006, s. 209-210
- [34] Ferraby S., The ecology of ruin sites [w:] *Conservation of Ruins*, ed. John Ashurst, Elsevier Science & Technology, 2006, s. 209-210
- [35] Frössel F.: *Osuszanie murów i renowacja piwnic*, Warszawa, POLCEN Sp. z o.o. 2007.
- [36] Further Reading and Contacts Biological Growths on Sandstone Buildings: Control & Treatment, Technical, Advice & Guidance, Technical Advice Notes, Historic Scotland, tom 10, 1997.
- [37] Galván-Ruiz M. , R. Velázquez-Castillo, M. A. Pérez-Lara, J. Arjona, J. L. Baños and M. E. Rodríguez-García, Chemical and physical characterization of stuccos from a Mexican colonial building: el Museo del Calendario of Queretaro, “*Archaeometry*”, vol. 51, 2009, s. 701-714.
- [38] Gołębniak A., Rola nowych technik dokumentacyjno-pomiarowych w interdyscyplinarnych działaniach badawczo-konserwatorskich, *Wiadomości Konserwatorskie*, nr 40/2014, s. 83-93
- [39] Gołka J., Haliński J., Fotogrametria cyfrowa w architekturze - nowe możliwości inwentaryzacji i archiwizacji obiektów, *Archiwum Fotogrametrii, Kartografii i Teledetekcji*, Vol. 10, 2000, s. 38-1:38-7

- [40] Gordon R. University. Biological Growths, Biocide Treatment, Soiling and Decay of Sandstone Buildings and Monuments in Scotland. Report on research commissioned. Historic Scotland and The Robert Gordon University, 1995.
- [41] Jabłoczyńska-Jędrzejewska H., Dawne zaprawy budowlane, „Kwartalnik Architektury i urbanistyki, t.3, z.1, 1958 , s.85-94.
- [42] Jachimski J., Fotogrametryczna inwentaryzacja obiektów zabytkowych, Archiwum Fotogrametrii, Kartografii i Teledetekcji, Vol. 7, 1997, s. 53-60,
- [43] Jasieńko J., Mierzejewska O., Hamrol K., Misztal W., Utrwalanie koron murów obiektów historycznych przeznaczonych do ekspozycji w formie trwałej ruiny, „Wiadomości konserwatorskie” nr 30, 2011, s. 117-132
- [44] Jasieńko J., Mierzejewska O., Hamrol K., Misztal W., Utrwalanie koron murów obiektów historycznych przeznaczonych do ekspozycji w formie trwałej ruiny, „Wiadomości konserwatorskie” nr 30, 2011, s. 117-132
- [45] Jaskowska-Lemańska, J., Czaja, J. Non-Destructive Testing Methods of Building Structures as Part of Reverse Logistics on the Example of Gorzanów Palace Renovation, Logistyka, 4359-4371, 2014
- [46] Karaszkiwicz P.: Sole w obiektach budowlanych, Materiały budowlane nr 8/2002
- [47] Klimkowska H., Wróbel. A., Uwagi o wykorzystaniu tachimetrów bezlustrowych w inwentaryzacji architektonicznej, Archiwum Fotogrametrii, Kartografii i Teledetekcji, Vol. 16, 2016,
- [48] Kozarski P., Molski P., Zagospodarowanie i konserwacja zabytkowych budowli. Towarzystwo Przyjaciół Fortyfikacji, Fortyfikacje tom XIV, Warszawa 2001
- [49] Kozarski P., Molski P., Zagospodarowanie i konserwacja zabytkowych budowli. Towarzystwo Przyjaciół Fortyfikacji, Fortyfikacje tom XIV, Warszawa 2001
- [50] Krzywobłocka R., Mikroskopowe metody badania materiałów budowlanych, ITB Warszawa 1966, mps.
- [51] Kwoczyńska B., Opracowanie obiektów architektonicznych z wykorzystaniem metod stosowanych w fotogrametrii cyfrowej, Infrastruktura i ekologia terenów wiejskich, nr 3/2010, Polska Akademia Nauk, Oddział w Krakowie, s.65-74
- [52] Lanas J. et al., Mechanical properties of masonry repair dolomitic lime-based plasters, Cement and Concrete Research, vol. 36, 5: 2006;s. 951-960.
- [53] Mazzocchin G.A, A. Vianello, S. Minghelli, D. Rudello, Analysis of Roman wall paintings from the thermae of ‘Iulia Concordia’, “Archaeometry”, vol. 52, 2010, s.644-655.
- [54] Oberc A., Zastosowanie mikroskopowych metod petrograficznych w pracach nad konserwacją zabytków, BMiOZ s.B, t.11, 1965, s. 69-78.
- [55] Ö-Norm B 3355 „Osuszanie murów”
- [56] Parat M., Schaaf Ulrich, Inwentaryzacja pomiarowo-rysunkowa zabytków architektury drewnianej w procesie konserwatorskim - problemy i propozycja standaryzacji, Budownictwo i Architektura, vol. 14(4), 2015, s. 99-110
- [57] PN-70/B-02365 - Powierzchnie budynków - Podział, określenia i zasady obmiaru,
- [58] PN-B-04500:1985 Zaprawy budowlane - Badania cech fizycznych i wytrzymałościowych.
- [59] PN-B-04500:1985 Zaprawy budowlane - Badania cech fizycznych i wytrzymałościowych
- [60] PN-B-12016:1970 Wyroby ceramiki budowlanej - Badania techniczne.
- [61] PN-EN 1015-11 Metody badań zapraw do murów. Określenie wytrzymałości na zginanie i ściskanie stwardniałej zaprawy.
- [62] PN-EN 1015-11:2001/A1:2007 Metody badań zapraw do murów - Część 11: Określenie wytrzymałości na zginanie i ściskanie stwardniałej zaprawy.
- [63] PN-EN 1015-18:2003 Metody badań zapraw do murów - Część 18: Określenie współczynnika absorpcji wody spowodowanej podciąganiem kapilarnym stwardniałej zaprawy.
- [64] PN-EN 1015-18:2003 Metody badań zapraw do murów - Część 18: Określenie współczynnika absorpcji wody spowodowanej podciąganiem kapilarnym stwardniałej zaprawy.
- [65] PN-EN 12370:2001 Metody badań kamienia naturalnego - Oznaczanie odporności na krystalizację soli.
- [66] PN-EN 12371:2002 Metody badań kamienia naturalnego - Oznaczanie mrozoodporności.

- [67] PN-EN 12372:2007 - wersja angielska Metody badań kamienia naturalnego. Oznaczanie wytrzymałości na zginanie pod wpływem siły skupionej.
- [68] PN-EN 13161:2008 - wersja angielska Metody badań kamienia naturalnego - Oznaczanie wytrzymałości na zginanie przy stałym momencie.
- [69] PN-EN 13755:2002/AC:2004 Metody badań kamienia naturalnego. Oznaczanie nasiąkliwości przy ciśnieniu atmosferycznym.
- [70] PN-EN 13892-2:2004 Metody badania materiałów na podkłady podłogowe - Część 2: Oznaczanie wytrzymałości na zginanie i ściskanie.
- [71] PN-EN 14157:2005 Kamień naturalny. Oznaczanie odporności na ścieranie.
- [72] PN-EN 1925:2001 Metody badań kamienia naturalnego - Oznaczanie współczynnika nasiąkliwości kapilarnej.
- [73] PN-EN 1926:2001 Metody badań kamienia naturalnego - Oznaczanie wytrzymałości na ściskanie.
- [74] PN-EN 1936:2001 Metody badań kamienia naturalnego - Oznaczanie gęstości i gęstości objętościowej oraz całkowitej i otwartej porowatości.
- [75] PN-EN 772-11:2002 Metody badań elementów murowych - Część 11: Określenie absorpcji wody elementów murowych z betonu kruszywowego, kamienia sztucznego i kamienia naturalnego spowodowanej podciąganiem kapilarnym oraz początkowej absorpcji wody elementów murowych ceramicznych.
- [76] PN-EN 772-21:2011 Metody badań elementów murowych - Część 21: Określanie absorpcji wody ceramicznych i silikatowych elementów murowych przez absorpcję zimnej wody.
- [77] PN-EN 772-4:2001 Metody badań elementów murowych - Część 4: Określenie gęstości, gęstości objętościowej oraz porowatości całkowitej i otwartej elementów murowych z kamienia naturalnego.
- [78] PN-EN 772-7:2000 Metody badań elementów murowych -- Określenie absorpcji wody przez elementy murowe ceramiczne stosowane w warstwach odpornych na wilgoć, za pomocą gotowania w wodzie.
- [79] PN-EN 998-2:2004/Ap1:2008 Wymagania dotyczące zapraw do murów - Część 2: Zaprawa murarska.
- [80] PN-EN ISO 12570 Ciepłno-wilgotnościowe właściwości materiałów i wyrobów budowlanych. Określanie wilgotności przez suszenie w podwyższonej temperaturze.
- [81] PN-ISO9836:1997 - Właściwości użytkowe w budownictwie - Określenie i obliczanie wskaźników powierzchniowych i kubaturowych.
- [82] Poksińska M., Materiały i technika dolnośląskich sztukaterii z drugiej połowy XVII wieku. Praca doktorska przygotowana pod kierunkiem prof. dr hab. Zbigniewa Brochwicza na Wydziale Sztuk Pięknych, Uniwersytet im. Mikołaja Kopernika [mps], Toruń 1982, sygn. 578
- [83] Poksińska M., Problemy identyfikacji związków organicznych w zabytkowych sztukateriach, [w:] Informator PKZ 1981, Chemia w konserwacji zabytków. Materiały z II Ogólnopolskiego Zjazdu Chemików Konserwatorów, Toruń -Bachotek wrzesień, 1981, s. 24-28.
- [84] Poksińska M., The technology of ancient mortars as a basis for contemporary re construction of historical plaster and stuccoes, [w:] Conservation et restoration des bines cultures. Preservation and Restoration of Cultural Heritage. Montreux 1995, s. 649-656.
- [85] Poksińska M., Wyrwa A. M., Kęsy-Lewandowska M., Technologia dawnych zapraw jako przyczynek do poznania chronologii faz budowy rotundy i kościoła cysterskiego w Łeknie, [w:] Studia i materiały do dziejów Pałuk. t. 3. Środowisko naturalne i osadnictwo w łekińskim kompleksie osadniczym. Pod red.A. M. Wyrwy, 2000, s. 368-390.
- [86] Praca zbiorowa pod redakcją Ważnego J., Karysia J. , Ochrona budynków przed korozją biologiczną Arkady, Warszawa 2001.
- [87] Praca zbiorowa pod redakcją Ważnego J., Karysia J. , Ochrona budynków przed korozją biologiczną Arkady, Warszawa 2001.
- [88] Prarat M., Wykorzystanie tachimetrii i fotogrametrii w dokumentacji zabytków architektury na przykładzie inwentaryzacji pomiarowo-rysunkowej wybranych kamienic toruńskich, Acta Universitatis Nicolai Copernici, No 46, 2015, s. 509-531

- [89] Quinlan M., Hanna M., Kelly D., The conservation and repair of masonry ruins, - Government of Ireland, Dublin, 2010
- [90] Quinlan M., Hanna M., Kelly D., The conservation and repair of masonry ruins, - Government of Ireland, Dublin, 2010
- [91] Rampazzi L., Rizzo B., Colombo C., Conti C., Realini M., Bartolucci U., Colombini M. P., Spiriti A., Facchin L., The stucco technique of the Magistri Comacini: the case study of Santa Maria dei Ghirli in Campione D'italia (Como, Italy)*Archaeometry (2012)
- [92] Rampazzia L., Rizzoa B., Colombob C., Contib C., Realinib M., Bartoluccic U., Colombinic Maria P.A., Spiritid A., Facchind L., The stucco decorations from St. Lorenzo in Laino (Como, Italy): The materials and the techniques employed by the "Magistri Comacini". "Analytica Chimica Acta", vol. 630, Issue 1, 2008, s. 91-100.
- [93] Rogóż J, Zastosowanie technik nieniszczących w badaniach konserwatorskich malowideł ściennych, Wydawnictwo Naukowe UMK, 2009, Toruń
- [94] Sansonetti A., J.Striova, D. Biondelli, E.M. Castellucci, Colored grounds of gilt stucco surfaces as analyzed by a combined microscopic, spectroscopic and elemental analytical approach, „Analytical and Bioanalytical Chemistry”, vol. 397, 2010, s.2667-76.
- [95] Sieniawska-Kuras A, Potocki P., Przyczyny zniszczeń obiektów budowlanych i elementów architektonicznych. Procesy biologiczne. [w:] Renowacja elementów architektury. Wydawnictwo i handel książkami „KaBe”, Krosno 2012, s. 53-55
- [96] Sieniawska-Kuras A, Potocki P., Przyczyny zniszczeń obiektów budowlanych i elementów architektonicznych. Procesy biologiczne. [w:] Renowacja elementów architektury. Wydawnictwo i handel książkami „KaBe”, Krosno 2012, s. 53-55
- [97] Skibiński S., Badania nad zaprawami budowlanymi, [w:] Materiały sprawozdawcze z badań zespołu pobenedyktynskiego w Mogilnie, BMiOZ, Seria B, z. 3, Warszawa 1983, s. 31.
- [98] Skibiński S., Badania składu fazowego i struktury kamiennych obiektów zabytkowych w ekspertyzie konserwatorskiej, [w:] Chemia w konserwacji zabytków. Materiały konferencyjne, 1982, s.160-170.
- [99] Skibiński S., Kęsy -Lewandowska M., Zastosowanie termicznej analizy różnicowej do badań zapraw budowlanych dla potrzeb archeologii i architektury [w:] ACTA, Archeologia XIII - Archeologia Architektury, Nauki humanistyczno- Społeczne, z. 184, 1990, s.104-150.
- [100] Skibiński S., Wyniki badań nad zaprawami pochodzącymi z pierwszej przebudowy kościoła oraz najwcześniejszych obwarowań klasztornych, [w:] Materiały sprawozdawcze z badań zespołu pobenedyktynskiego w Mogilnie, BMiOZ, Seria B, t. 60, z. 2, 1980, s. 76-83.
- [101] Skibiński S., Wyniki badań próbek zapraw budowlanych, [w:] Materiały sprawozdawcze z badań zespołu pobenedyktynskiego w Mogilnie, BMiOZ, Seria B, z. 3, Warszawa 1983, s. 37- 44.
- [102] Skibiński S.: Sole rozpuszczalne w wodzie, Renowacje nr 10/2000.
- [103] Strzelczyk A. B., Czynniki niszczące kamienie. Czynniki biologiczne, [w:] Zabytki kamienne i metalowe ich niszczenie i konserwacja profilaktyczna, red. Wiesław Domastowski. Wydawnictwo Naukowe UMK, Toruń 2011, s.135-157
- [104] Strzelczyk A. B., Czynniki niszczące kamienie. Czynniki biologiczne, [w:] Zabytki kamienne i metalowe ich niszczenie i konserwacja profilaktyczna, red. Wiesław Domastowski. Wydawnictwo Naukowe UMK, Toruń 2011, s.135-157
- [105] Szymgin B., Wprowadzenie, Trwała ruina II. Problemy utrzymania i adaptacji. Ochrona, konserwacja i adaptacja zabytkowych murów, Lublin-Warszawa, 2010, s. 5-6
- [106] Tajchman J., Standardy w zakresie projektowania, realizacji i nadzorów prac konserwatorskich dotyczących zabytków architektury i budownictwa, Narodowy Instytut Dziedzictwa, Warszawa, 2014,
- [107] Tajchman J.: Metoda zabezpieczania i rewitalizacji ruin historycznych jako szczególny rodzaj konserwacji i restauracji zabytków architektury, Materiały z międzynarodowej konferencji naukowej, Gubin 2008.
- [108] Tajchman J.: Metoda zabezpieczania i rewitalizacji ruin historycznych jako szczególny rodzaj konserwacji i restauracji zabytków architektury, Materiały z międzynarodowej konferencji naukowej, Gubin 2008.

- [109] Trizio I., GIS-technologies and Cultural Heritage: stocktaking, documentation and management. In *Rethinking Cultural Heritage, Experiences from Europe and Asia*, Dresden: TechnischeUniversität Dresden, 2007, s. 75-91
- [110] Trochonowicz M.: *Obiekty murowe w ruinie. Wpływ czynników degradujących na ich zachowanie, Trwała ruina II. Problemy utrzymania i adaptacji. Ochrona, konserwacja i adaptacja zabytkowych murów*, Lublin- Warszawa, LTN, Politechnika Lubelska, PKN ICOMOS, 2010.
- [111] Trochonowicz M.: *Zamek w Janowcu nad Wisłą. Ocena stanu wilgotnościowego i zasolenia murów*. Politechnika Lubelska, Lublin 2006.
- [112] Trochonowicz M.: *Zamek w Janowcu nad Wisłą. Ocena stanu wilgotnościowego i zasolenia murów*. Politechnika Lubelska, Lublin 2006.
- [113] Uścińowicz J., Standards of conservation documentation of wooden architecture facilities as a basis for monitoring and management, *Documentation and the monitoring in managing timber objects in Krzysztof Kluk Museum of Agriculture in Ciechanowiec and the Ryfylke Museum, Krzysztof Kluk Museum of Agriculture in Ciechanowiec*, 2015, s. 43-67
- [114] Wirska-Parachowiak M., Z historii wiążących materiałów budowlanych, „Ochrona Zabytków”, Nr 4, 1956, s.17-23.
- [115] Wójcik J., Skibiński S., Próba rozpoznania surowców skalnych zastosowanych w sklepieniach krypt romańskich w Moginie [w:] *Materiały sprawozdawcze z badań zespołu pobenedyktynskiego w Mogilnie*. BMiOZ Seria B z.2 , 1980, s.52-71.
- [116] Wouters J., M. Van Bos,K. Lamens, Baroque stucco marble decorations. II. Composition and degradation of the organic materials in historical samples and implications for their conservation, „Studies in Conservation”, vol. 45, 2000, s. 169-179.
- [117] WTA 2-9-04/D „Systemy tynków renowacyjnych”
- [118] Wytyczne Techniczne G-3.4, Inwentaryzacja zespołów urbanistycznych, zespołów zieleni i obiektów architektury, GUGiK, Warszawa, 1981,
- [119] Young M., Wakefield R., Research commission investigating biological growths, biocide treatment soiling and decay of sandstone buildings and monuments in Scotland. 1995

Websites:

- [120] <http://geo-metric.com/fotogrametria-cyfrowa>, data odczytu: 24.07.2018 r.,
- [121] <http://www.wrogeo.pl/pl/fotogrametria.html>, data odczytu: 24.07.2018 r.,

ISBN: 978-83-7947-420-2

